

CAEP

Submittal Documents

Seismic Analysis of the Boiler SF-550



June 24, 2019

For:
WEIL-McLAIN

Prepared By:
Sam Salissen, ME, PE, Ph.D.

Summary

The scope of this report is the seismic qualification, based on the structural analysis, of the Slim Fit boiler model 550, under the seismic loads for the seismic zone 4 in the United States. The analyses are limited to the load path from the COG of the assembly to the floor and the interior parts of the boiler are not within the scope of this work.

The qualification is in accordance with the seismic design requirements of IBC 2015, ASCE 7-10 and AISC 14th edition for the seismic zone 4, for non-structural components and based on the seismic parameters used in this report.

The structural analyses carried out on the base frame assembly and based on the safety factors reported in section 5.4, the design requirements of AISC, is met in all the analyses performed in this report.

It is concluded that the design of the main frame and seismic stands meets the design requirements of IBC 2015, ASCE 7-10 and ASME BPVC and AISC standards. This conclusion is contingent to the accuracy of the SolidWorks model and other input data provided by WEIL-McLAIN (WM) and used to build the FE models and set up the analyses (material, COG,...) appended in Appendix 1.

Revision History

| Rev | Date | Scope of the revision | Created by |
|-----|------------|-----------------------|--------------|
| A | 06/24/2019 | First Issue | Sam Salissen |

Table of Contents

| | | |
|-------|---|----|
| 1 | Introduction | 6 |
| 1.1 | Scope | 6 |
| 2 | Assumptions and open issues | 6 |
| 3 | Requirements and Prerequisites..... | 7 |
| 3.1 | Stress criteria | 7 |
| 3.2 | Loads | 7 |
| 4 | Analyses' model | 9 |
| 4.1 | The extent of the model..... | 9 |
| 4.2 | Material data..... | 9 |
| 5 | Stress Analyses..... | 10 |
| 5.1 | Analysis of assembly: Load Case 1 | 10 |
| 5.2 | Analysis of assembly: Load Case 2 | 11 |
| 5.3 | Analysis of assembly: Load Case 3 | 12 |
| 5.3.1 | Anchor Bolts | 14 |
| 5.4 | Results Evaluation..... | 14 |
| 6 | Conclusion | 15 |
| 7 | References | 16 |

APPENDICES

APPENDIX 1- Overall dimension of the boilers

APPENDIX 2- Anchor Bolt Calculation Report

1 Introduction

1.1 Scope

The scope of this report is the seismic qualification, based on the structural analysis, of the Slim Fit boiler model 550, under the seismic loads for the seismic zone 4 in the states. The analyses are limited to the load path from the COG of the assembly to the floor and the interior parts of the boiler are not within the scope of this work. The qualification is in accordance with the design requirements of IBC 2015, ASCE 7-10 and AISC.

2 Assumptions and open issues

In this chapter, assumptions and open issues are presented in two categories. The definition of each is presented below.

Open issues- Is defined as issues that must be solved, otherwise the analysis cannot be completed.

Key assumption- Is defined as assumptions that may have noticeable impact on the analysis results.

2.1 Open Issues

- No open issues exist.

2.2 Key Assumptions

No fabrication drawing of the parts and assembly were provided and the analyses are based on the SolidWorks model that is provided by WM and no responsibility of the accuracy of the model with respect to the actual assembly will be taken by the author of this report.

- The weight and the location of the center of the gravity of the boiler assembly are estimated and provided by WM, Appendix 1.
- It is assumed that the material of the base frame and the top plate are S235JR.
- It is assumed that the welds have at least the same strength as the base material (Weld strength $F_{EXX} = 70 \text{ksi} > 54 \text{ksi}$ for base material) based on ASME allowable stress in welds under shear and tension is $0.3 \times \text{tensile strength} = 21000 \text{psi}$. In this case it is lower than the allowable stress of the in the members (AISC). So, no weld analysis will be performed in this work.
- It is assumed that no load will be transferred from the connecting piping system to the boiler during a seismic event, flex joint will be needed at the connection points.

3 Requirements and Prerequisites

3.1 Stress criteria

The seismic loads are calculated based on the IBC 2015 code. The detail of the used parameters and the calculations are as follows. Seismic analyses are performed (using FEM) based on ASD approach of the AISC 14 edition & ASCE 7-10 for the steel parts and LRFD for the anchorage calculations.

3.2 Loads

The following inputs are used for the weight of the boilers.

| Boiler Model | Shipping weight | Operating weight | Water content | Water flow rate per boiler | | Vent/air pipe size – Provide a separate vent for each boiler | Electrical service required |
|---------------|-------------------|-----------------------------|--------------------|----------------------------|-----------------|--|---------------------------------------|
| | Pounds per boiler | Pounds per boiler Note 2 | Gallons per boiler | GPM @ 30°F rise | GPM @ 40°F rise | | Amps per boiler Note 4 |
| SF-550 | 505 | 476 | 5.5 | 34 | 26 | 6" or 8" | 25 (boiler) 15 (Boiler Circulator) |
| SF-750 | 550 | 529 | 6.5 | 47 | 35 | 6" or 8" | 25 (boiler) 15 (Boiler Circulator) |

Three load cases are considered in this report, the analyses are based on the worst load combinations specified in ASCE 7-10. The following parameters are used in calculation of the seismic loads as follows:

- 1- Load case 1: Used for the analyses of the steel parts



14271 Jeffrey Rd,
Irvine, CA 90032
PH (949) 923 9073 FX (949) 264 7184
www.caepiping.com
"CALL US - TO SET THINGS RIGHT"

JOB NAME:
SA-SF 750

CUSTOMER:
WEIL-McLAIN

| DATE | PRP. BY.: | CAE PIPING JOB #: |
|-----------|-----------|-------------------|
| 6/24/2019 | | |

SEISMIC CALCULATION WORKSHEET

BUILDING CODE:
IBC-2012 / 2015

SEISMIC DESIGN: 2 BLDG. ELEVATION:
/ EQUIP. LOCATION:

$S_{ds} = 2$ $h = 40$ ft
 $I_p = 1$ $z = 40$ ft
 $a_p = 1$ **** Assume worst**
 $R_p = 2.5$ case/location.
 $\Omega_o = 2.0$ a_p, R_p, Ω_o per ASCE 7-10

40 ft. RF
 0 ft. GF
 or below ground

LOAD COMBINATION
LRFD
(1.2 DL + 1.00 E)

| EQUIPMENT TAG: | APPLIED SEISMIC FORCE/ CALCULATIONS: | ANCHORAGE TO CONCRETE | SHT. NUMBER: |
|----------------|---|-----------------------|--------------|
| SLIM FIT 2000 | $F_p / W_p = (0.4 \times a_p \times S_{ds} \times (1 + (2 \times (z / h))) / (R_p / I_p)) = 0.96$ $F_p / W_p = 0.96g$; $F_{p,min} / W_p = 0.3$ $\times S_{ds} \times I_p = 0.60$; $F_{p,max} / W_p = 1.6 \times S_{ds} \times I_p = 3.20$ $F_{ph} = \text{Applied Lateral Seismic Force} = 1.0$ $\times 0.96g \times W_p = 528$ lbs. "WORST CASE" $F_{pv} = \text{Vertical component of seismic force} = 1.0$ $\times 0.2 \times S_{ds} \times W_p = 220$ lbs. "WORST CASE" $F_v = \text{Vertical total load} = F_{pv} - .9W_p = -275$ lbs. | | 1 OF 1 |

2- Load case 2: Used for the analyses of the steel parts



14271 Jeffery Rd.
Irvine, CA 90032
PH (949) 923 9073 FX (949) 264 7184
www.caepiping.com
"CALL US - TO SET THINGS RIGHT"

JOB NAME: SA-SF 750

CUSTOMER: WEIL-McLAIN

DATE: 6/24/2019 PRP. BY: CAE PIPING JOB #

SEISMIC CALCULATION WORKSHEET

BUILDING CODE: IBC-2012 / 2015

SEISMIC DESIGN: $S_{ds} = 2$

BLDG. ELEVATION / EQUIP. LOCATION: $h = 40$ ft

$I_p = 1$ $a_p = 1$ $R_p = 2.5$ $\Omega_o = 2.0$

** Assume worst case location

a_p, R_p, Ω_o per ASCE 7-10

EQUIPMENT TAG: SLIM FIT 2000

ANCHORAGE TO CONCRETE: [X] 40 ft. RF [] 0 ft. GF

or below ground

LOAD COMBINATION: LRFD (0.9 DL + 1.00 E)

APPLIED SEISMIC FORCE/ CALCULATIONS:

EQUIPMENT Information: $W_p = \text{max. operating weight} = 550 \text{ lbs.}$

$F_p / W_p = (0.4 \times a_p \times S_{ds} \times (1 + (2 \times (z / h))) / (R_p / I_p)) = 0.96$

$F_p / W_p = 0.96g$; $F_{p,min} / W_p = 0.3$ $\times S_{ds} \times I_p = 0.60$; $F_{p,max} / W_p = 1.6 \times S_{ds} \times I_p = 3.20$

$F_{ph} = \text{Applied Lateral Seismic Force} = 1.0 \times 0.96g \times W_p = 528 \text{ lbs.}$ *WORST CASE

$F_{pv} = \text{Vertical component of seismic force} = 1.0 \times 0.2 \times S_{ds} \times W_p = 220 \text{ lbs.}$ *WORST CASE

$F_v = \text{Vertical total load} = F_{pv} - 9W_p = -275 \text{ lbs.}$

ANCHORAGE TO CONCRETE: SHT. NUMBER: 1 OF 1

3- Load case 3: Used in the analyses of the anchorage



14271 Jeffery Rd.
Irvine, CA 90032
PH (949) 923 9073 FX (949) 264 7184
www.caepiping.com
"CALL US - TO SET THINGS RIGHT"

JOB NAME: SA-SF 750

CUSTOMER: WEIL-McLAIN

DATE: 6/24/2019 PRP. BY: CAE PIPING JOB #

SEISMIC CALCULATION WORKSHEET

BUILDING CODE: IBC-2012 / 2015

SEISMIC DESIGN: $S_{ds} = 2$

BLDG. ELEVATION / EQUIP. LOCATION: $h = 40$ ft

$I_p = 1$ $a_p = 1$ $R_p = 2.5$ $\Omega_o = 2.0$

** Assume worst case location

a_p, R_p, Ω_o per ASCE 7-10

EQUIPMENT TAG: SLIM FIT 2000

ANCHORAGE TO CONCRETE: [X] 40 ft. RF [] 0 ft. GF

or below ground

LOAD COMBINATION: LRFD 2013 (0.9 DL + 2.50 E)

APPLIED SEISMIC FORCE/ CALCULATIONS:

EQUIPMENT Information: $W_p = \text{max. operating weight} = 550 \text{ lbs.}$

$F_p / W_p = (0.4 \times a_p \times S_{ds} \times (1 + (2 \times (z / h))) / (R_p / I_p)) = 0.96$

$F_p / W_p = 0.96g$; $F_{p,min} / W_p = 0.3$ $\times S_{ds} \times I_p = 0.60$; $F_{p,max} / W_p = 1.6 \times S_{ds} \times I_p = 3.20$

$F_{ph} = \text{Applied Lateral Seismic Force} = 2.5 \times 0.96g \times W_p = 1320 \text{ lbs.}$ *WORST CASE

$F_{pv} = \text{Vertical component of seismic force} = 1.0 \times 0.2 \times S_{ds} \times W_p = 220 \text{ lbs.}$ *WORST CASE

$F_v = \text{Vertical total load} = F_{pv} - 9W_p = -275 \text{ lbs.}$

ANCHORAGE TO CONCRETE: SHT. NUMBER: 1 OF 1

The seismic (& dead weights) loads are applied at the location of the center of the gravity of boiler's assembly, using rigid elements, see Fig. 1.

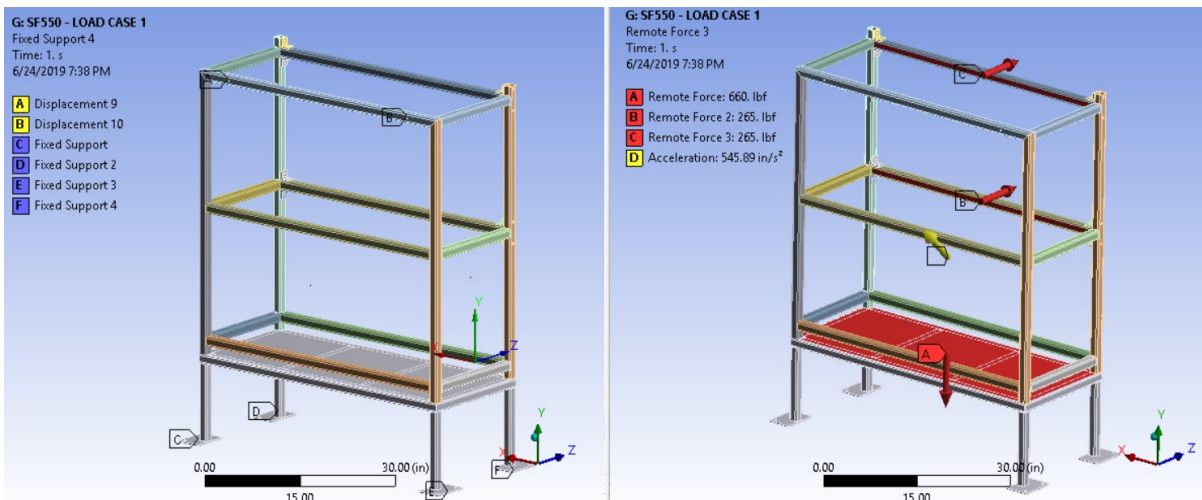

Figure 1- Loads acting on the boiler structure

5.3.1 Bolts

Hilti KBZ anchor bolts, 3/8" (2 3/4" embedment), are used to anchor the base plates to the floor and the side tube to the wall. The maximum reaction loads at the location of the joints are extracted from the FE-analyses (load case 3 above). The detail of the anchor bolt calcs are provided in Appendix 3. The minimum concrete thickness of 5" and PSI rating of 3.000 psi are considered in the analyses).

Table-3: Reaction loads in the base plate

| Reaction forces [lbf] | | | Reaction moments [lbf-ft] | | |
|--------------------------|----|-----|------------------------------|----|----|
| FX | FY | FZ | MX | MY | MZ |
| 35 | 37 | 175 | 132 | 14 | 20 |

Table-4: Reaction loads in the side anchor bolts

| Reaction forces [lbf] | | |
|--------------------------|----|-----|
| FX | FY | FZ |
| 5 | 38 | 548 |

3/8" grade 5 steel bolts are needed for jointing the angles to the longitudinal tubes in front of the frame. The maximum reaction loads on these bolts are listed in the following.

Table-5: Reaction loads in the bolts of angles holding the longitudinal tubes

| Reaction forces [lbf] | | |
|--------------------------|----|----|
| FX | FY | FZ |
| 174 | 6 | 10 |

5.4 Results Evaluation

Minimum required strength specified in ASCE is obtained in the analyses of the supporting frame assembly carried out in sections 5.1 to 5.4. The stresses reported in section 5 are the local stresses and the average stress through the thickness of the members are much lower and that can be shown by stress linearization through the thickness. However, since even the maximum local peak stresses don't exceed the allowable values, the stress linearization work is skipped here.

6 Conclusion

Seismic analysis of the boiler, model SF 750, is carried out in this report and based on the safety factors reported in section 5.4, minimum required strength factor is obtained in all the analyses performed in this report.

It is concluded that the design of the structure of the boiler SF-1000 meets the design requirements of AISC, ASCE7-10 and IBC 2012 standards.

7 References

[1]- IBC 2012.

[2]- AISC 14th Edition.

[3]- ASCE 7-10.

APPENDIX 1- Overall dimensions of boiler

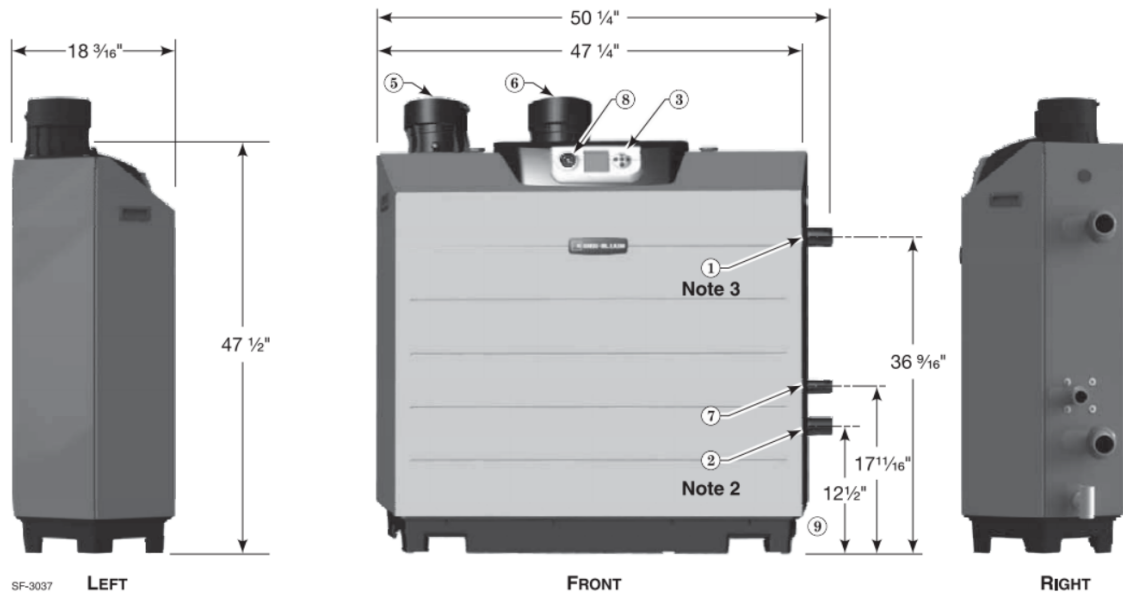

Appendix 2- Anchor Bolt Calculation

www.hilti.us

Company: CAE PIPING
 Specifier: SAM SALISSEN
 Address:
 Phone | Fax: |
 E-Mail:

Page: 1
 Project: ANCHOR BOLTS
 Sub-Project | Pos. No.:
 Date: 6/24/2019

Specifier's comments:
1 Input data

| | |
|----------------------------------|--|
| Anchor type and diameter: | Kwik Bolt TZ - CS 3/8 (2 3/4) |
| Effective embedment depth: | $h_{ef,act} = 2.750$ in., $h_{nom} = 3.063$ in. |
| Material: | Carbon Steel |
| Evaluation Service Report: | ESR-1917 |
| Issued Valid: | 6/1/2016 5/1/2017 |
| Proof: | Design method ACI 318-14 / Mech. |
| Stand-off installation: | $e_b = 0.000$ in. (no stand-off); $t = 0.250$ in. |
| Anchor plate: | $l_x \times l_y \times t = 4.000$ in. \times 6.000 in. \times 0.250 in.; (Recommended plate thickness: not calculated) |
| Profile: | no profile |
| Base material: | cracked concrete, 2500, $f'_c = 2500$ psi; $h = 5.000$ in. |
| Installation: | hammer drilled hole, Installation condition: Dry |
| Reinforcement: | tension: condition B, shear: condition B; no supplemental splitting reinforcement present edge reinforcement: none or < No. 4 bar |

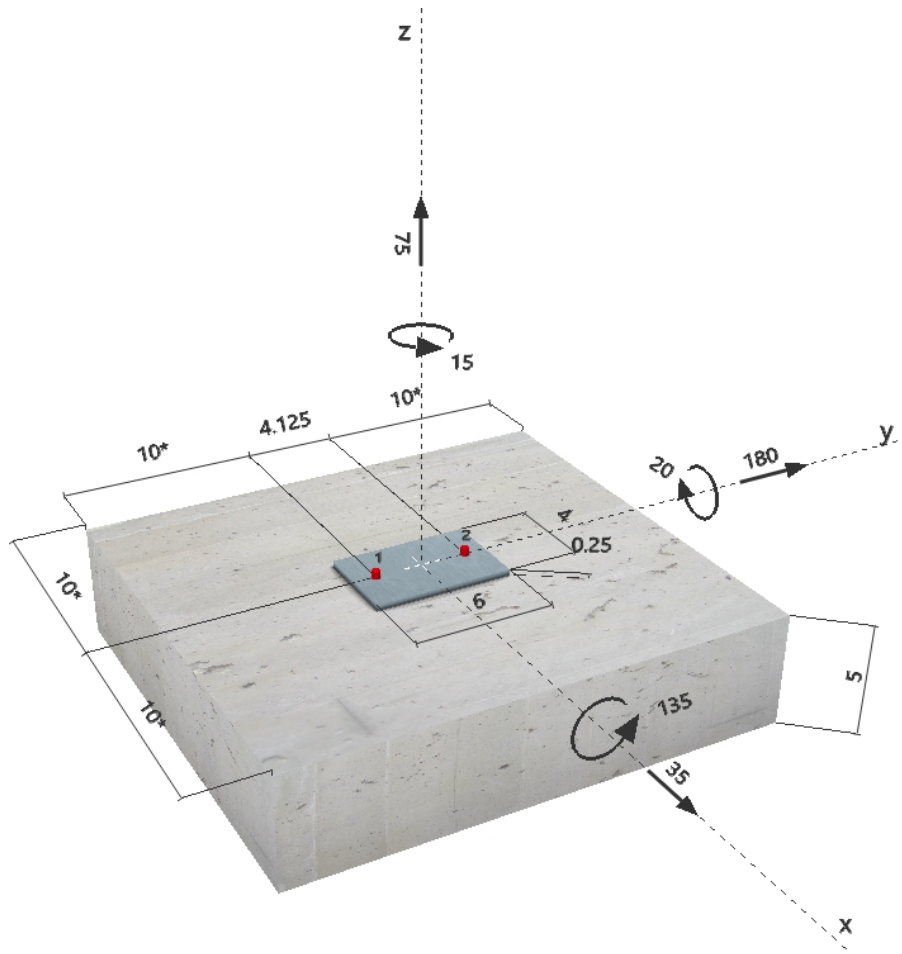
Geometry [in.] & Loading [lb, ft.lb]

www.hilti.us

Company: CAE PIPING
 Specifier: SAM SALISSEN
 Address:
 Phone | Fax: |
 E-Mail:

Page: 2
 Project: ANCHOR BOLTS
 Sub-Project | Pos. No.:
 Date: 6/24/2019

2 Load case/Resulting anchor forces

Load case: Design loads

Anchor reactions [lb]

Tension force: (+Tension, -Compression)

| Anchor | Tension force | Shear force | Shear force x | Shear force y |
|--------|---------------|-------------|---------------|---------------|
| 1 | 17 | 109 | 61 | 90 |
| 2 | 381 | 94 | -26 | 90 |

max. concrete compressive strain: 0.07 [‰]
 max. concrete compressive stress: 311 [psi]
 resulting tension force in (x/y)=(0.000/1.889): 398 [lb]
 resulting compression force in (x/y)=(0.744/-2.692): 323 [lb]

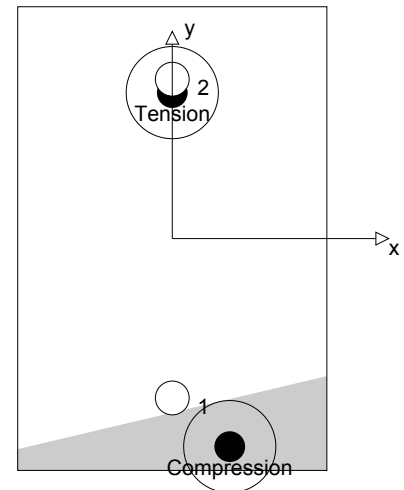

3 Tension load

| | Load N_{ua} [lb] | Capacity ϕN_n [lb] | Utilization $\beta_N = N_{ua}/\phi N_n$ | Status |
|------------------------------|--------------------|--------------------------|---|--------|
| Steel Strength* | 381 | 4875 | 8 | OK |
| Pullout Strength* | 381 | 2051 | 19 | OK |
| Concrete Breakout Strength** | 398 | 2592 | 16 | OK |

* anchor having the highest loading **anchor group (anchors in tension)

3.1 Steel Strength

N_{sa} = ESR value refer to ICC-ES ESR-1917
 $\phi N_{sa} \geq N_{ua}$ ACI 318-14 Table 17.3.1.1

Variables

| $A_{se,N}$ [in. ²] | f_{uta} [psi] |
|--------------------------------|-----------------|
| 0.05 | 125000 |

Calculations

| |
|---------------|
| N_{sa} [lb] |
| 6500 |

Results

| N_{sa} [lb] | ϕ_{steel} | ϕN_{sa} [lb] | N_{ua} [lb] |
|---------------|----------------|--------------------|---------------|
| 6500 | 0.750 | 4875 | 381 |

www.hilti.us

Company: CAE PIPING
 Specifier: SAM SALISSEN
 Address:
 Phone | Fax: |
 E-Mail:

Page: 3
 Project: ANCHOR BOLTS
 Sub-Project | Pos. No.:
 Date: 6/24/2019

3.2 Pullout Strength

$$N_{pn,f_c} = N_{p,2500} \lambda_a \sqrt{\frac{f'_c}{2500}} \quad \text{refer to ICC-ES ESR-1917}$$

$$\phi N_{pn,f_c} \geq N_{ua} \quad \text{ACI 318-14 Table 17.3.1.1}$$

Variables

| f'_c [psi] | λ_a | $N_{p,2500}$ [lb] |
|--------------|-------------|-------------------|
| 2500 | 1.000 | 3155 |

Calculations

$$\frac{\sqrt{\frac{f'_c}{2500}}}{1.000}$$

Results

| N_{pn,f_c} [lb] | $\phi_{concrete}$ | $\phi N_{pn,f_c}$ [lb] | N_{ua} [lb] |
|-------------------|-------------------|------------------------|---------------|
| 3155 | 0.650 | 2051 | 381 |

3.3 Concrete Breakout Strength

$$N_{cbg} = \left(\frac{A_{Nc}}{A_{Nc0}} \right) \psi_{ec,N} \psi_{ed,N} \psi_{c,N} \psi_{cp,N} N_b \quad \text{ACI 318-14 Eq. (17.4.2.1b)}$$

$$\phi N_{cbg} \geq N_{ua} \quad \text{ACI 318-14 Table 17.3.1.1}$$

$$A_{Nc} \text{ see ACI 318-14, Section 17.4.2.1, Fig. R 17.4.2.1(b)}$$

$$A_{Nc0} = 9 h_{ef}^2 \quad \text{ACI 318-14 Eq. (17.4.2.1c)}$$

$$\psi_{ec,N} = \left(\frac{1}{1 + \frac{2 e_{c,N}}{3 h_{ef}}} \right) \leq 1.0 \quad \text{ACI 318-14 Eq. (17.4.2.4)}$$

$$\psi_{ed,N} = 0.7 + 0.3 \left(\frac{c_{a,min}}{1.5 h_{ef}} \right) \leq 1.0 \quad \text{ACI 318-14 Eq. (17.4.2.5b)}$$

$$\psi_{cp,N} = \text{MAX} \left(\frac{c_{a,min}}{c_{ac}}, \frac{1.5 h_{ef}}{c_{ac}} \right) \leq 1.0 \quad \text{ACI 318-14 Eq. (17.4.2.7b)}$$

$$N_b = k_c \lambda_a \sqrt{f'_c} h_{ef}^{1.5} \quad \text{ACI 318-14 Eq. (17.4.2.2a)}$$

Variables

| h_{ef} [in.] | $e_{c1,N}$ [in.] | $e_{c2,N}$ [in.] | $c_{a,min}$ [in.] | $\psi_{c,N}$ |
|----------------|------------------|------------------|-------------------|--------------|
| 2.750 | 0.000 | 1.889 | 10.000 | 1.000 |

| c_{ac} [in.] | k_c | λ_a | f'_c [psi] |
|----------------|-------|-------------|--------------|
| 4.125 | 17 | 1.000 | 2500 |

Calculations

| A_{Nc} [in. ²] | A_{Nc0} [in. ²] | $\psi_{ec1,N}$ | $\psi_{ec2,N}$ | $\psi_{ed,N}$ | $\psi_{cp,N}$ | N_b [lb] |
|------------------------------|-------------------------------|----------------|----------------|---------------|---------------|------------|
| 102.09 | 68.06 | 1.000 | 0.686 | 1.000 | 1.000 | 3876 |

Results

| N_{cbg} [lb] | $\phi_{concrete}$ | ϕN_{cbg} [lb] | N_{ua} [lb] |
|----------------|-------------------|---------------------|---------------|
| 3988 | 0.650 | 2592 | 398 |

www.hilti.us

 Company: CAE PIPING
 Specifier: SAM SALISSEN
 Address:
 Phone | Fax: |
 E-Mail:

 Page: 4
 Project: ANCHOR BOLTS
 Sub-Project | Pos. No.:
 Date: 6/24/2019

4 Shear load

| | Load V_{ua} [lb] | Capacity ϕV_n [lb] | Utilization $\beta_V = V_{ua}/\phi V_n$ | Status |
|---|--------------------|--------------------------|---|--------|
| Steel Strength* | 109 | 2337 | 5 | OK |
| Steel failure (with lever arm)* | N/A | N/A | N/A | N/A |
| Pryout Strength* | 109 | 4070 | 3 | OK |
| Concrete edge failure in direction y+** | 190 | 2720 | 7 | OK |

* anchor having the highest loading **anchor group (relevant anchors)

4.1 Steel Strength

 V_{sa} = ESR value refer to ICC-ES ESR-1917
 $\phi V_{steel} \geq V_{ua}$ ACI 318-14 Table 17.3.1.1

Variables

| | |
|--------------------------------|-----------------|
| $A_{se,V}$ [in. ²] | f_{uta} [psi] |
| 0.05 | 125000 |

Calculations

| |
|---------------|
| V_{sa} [lb] |
| 3595 |

Results

| | | | |
|---------------|----------------|--------------------|---------------|
| V_{sa} [lb] | ϕ_{steel} | ϕV_{sa} [lb] | V_{ua} [lb] |
| 3595 | 0.650 | 2337 | 109 |

4.2 Pryout Strength

$$V_{cp} = k_{cp} \left[\left(\frac{A_{Nc}}{A_{Nc0}} \right) \Psi_{ed,N} \Psi_{c,N} \Psi_{cp,N} N_b \right] \quad \text{ACI 318-14 Eq. (17.5.3.1a)}$$

$$\phi V_{cp} \geq V_{ua} \quad \text{ACI 318-14 Table 17.3.1.1}$$

$$A_{Nc} \text{ see ACI 318-14, Section 17.4.2.1, Fig. R 17.4.2.1(b)}$$

$$A_{Nc0} = 9 h_{ef}^2 \quad \text{ACI 318-14 Eq. (17.4.2.1c)}$$

$$\Psi_{ec,N} = \left(\frac{1}{1 + \frac{2 e_N}{3 h_{ef}}} \right) \leq 1.0 \quad \text{ACI 318-14 Eq. (17.4.2.4)}$$

$$\Psi_{ed,N} = 0.7 + 0.3 \left(\frac{c_{a,min}}{1.5 h_{ef}} \right) \leq 1.0 \quad \text{ACI 318-14 Eq. (17.4.2.5b)}$$

$$\Psi_{cp,N} = \text{MAX} \left(\frac{c_{a,min}}{c_{ac}}, \frac{1.5 h_{ef}}{c_{ac}} \right) \leq 1.0 \quad \text{ACI 318-14 Eq. (17.4.2.7b)}$$

$$N_b = k_c \lambda_a \sqrt{f'_c} h_{ef}^{1.5} \quad \text{ACI 318-14 Eq. (17.4.2.2a)}$$

Variables

| | | | | |
|----------|----------------|------------------|------------------|-------------------|
| k_{cp} | h_{ef} [in.] | $e_{c1,N}$ [in.] | $e_{c2,N}$ [in.] | $c_{a,min}$ [in.] |
| 2 | 2.750 | 0.000 | 0.000 | 10.000 |

| | | | | |
|--------------|----------------|-------|-------------|--------------|
| $\Psi_{c,N}$ | c_{ac} [in.] | k_c | λ_a | f'_c [psi] |
| 1.000 | 4.125 | 17 | 1.000 | 2500 |

Calculations

| | | | | | | |
|------------------------------|-------------------------------|----------------|----------------|---------------|---------------|------------|
| A_{Nc} [in. ²] | A_{Nc0} [in. ²] | $\Psi_{ec1,N}$ | $\Psi_{ec2,N}$ | $\Psi_{ed,N}$ | $\Psi_{cp,N}$ | N_b [lb] |
| 51.05 | 68.06 | 1.000 | 1.000 | 1.000 | 1.000 | 3876 |

Results

| | | | |
|---------------|-------------------|--------------------|---------------|
| V_{cp} [lb] | $\phi_{concrete}$ | ϕV_{cp} [lb] | V_{ua} [lb] |
| 5814 | 0.700 | 4070 | 109 |

www.hilti.us

Company: CAE PIPING
 Specifier: SAM SALISSEN
 Address:
 Phone | Fax: |
 E-Mail:

Page: 5
 Project: ANCHOR BOLTS
 Sub-Project | Pos. No.:
 Date: 6/24/2019

4.3 Concrete edge failure in direction y+

$$V_{cbg} = \left(\frac{A_{Vc}}{A_{Vc0}} \right) \Psi_{ec,V} \Psi_{ed,V} \Psi_{c,V} \Psi_{h,V} \Psi_{parallel,V} V_b \quad \text{ACI 318-14 Eq. (17.5.2.1b)}$$

$$\phi V_{cbg} \geq V_{ua} \quad \text{ACI 318-14 Table 17.3.1.1}$$

A_{Vc} see ACI 318-14, Section 17.5.2.1, Fig. R 17.5.2.1(b)

$$A_{Vc0} = 4.5 c_{a1}^2 \quad \text{ACI 318-14 Eq. (17.5.2.1c)}$$

$$\Psi_{ec,V} = \left(\frac{1}{1 + \frac{2e_v}{3c_{a1}}} \right) \leq 1.0 \quad \text{ACI 318-14 Eq. (17.5.2.5)}$$

$$\Psi_{ed,V} = 0.7 + 0.3 \left(\frac{c_{a2}}{1.5c_{a1}} \right) \leq 1.0 \quad \text{ACI 318-14 Eq. (17.5.2.6b)}$$

$$\Psi_{h,V} = \sqrt{\frac{1.5c_{a1}}{h_a}} \geq 1.0 \quad \text{ACI 318-14 Eq. (17.5.2.8)}$$

$$V_b = \left(7 \left(\frac{l_e}{d_a} \right)^{0.2} \sqrt{d_a} \right) \lambda_a \sqrt{f_c} c_{a1}^{1.5} \quad \text{ACI 318-14 Eq. (17.5.2.2a)}$$

Variables

| c_{a1} [in.] | c_{a2} [in.] | e_{cV} [in.] | $\Psi_{c,V}$ | h_a [in.] |
|----------------|----------------|----------------|--------------|---------------------|
| 6.667 | 10.000 | 0.000 | 1.000 | 5.000 |
| l_e [in.] | λ_a | d_a [in.] | f_c [psi] | $\Psi_{parallel,V}$ |
| 2.750 | 1.000 | 0.375 | 2500 | 1.000 |

Calculations

| A_{Vc} [in. ²] | A_{Vc0} [in. ²] | $\Psi_{ec,V}$ | $\Psi_{ed,V}$ | $\Psi_{h,V}$ | V_b [lb] |
|------------------------------|-------------------------------|---------------|---------------|--------------|------------|
| 100.00 | 200.00 | 1.000 | 1.000 | 1.414 | 5495 |

Results

| V_{cbg} [lb] | $\phi_{concrete}$ | ϕV_{cbg} [lb] | V_{ua} [lb] |
|----------------|-------------------|---------------------|---------------|
| 3886 | 0.700 | 2720 | 190 |

5 Combined tension and shear loads

| β_N | β_V | ζ | Utilization $\beta_{N,V}$ [%] | Status |
|-----------|-----------|---------|-------------------------------|--------|
| 0.186 | 0.070 | 5/3 | 8 | OK |

$$\beta_{NV} = \beta_N^{\zeta} + \beta_V^{\zeta} \leq 1$$

6 Warnings

- Load re-distributions on the anchors due to elastic deformations of the anchor plate are not considered. The anchor plate is assumed to be sufficiently stiff, in order not to be deformed when subjected to the loading! Input data and results must be checked for agreement with the existing conditions and for plausibility!
- Condition A applies when supplementary reinforcement is used. The Φ factor is increased for non-steel Design Strengths except Pullout Strength and Pryout strength. Condition B applies when supplementary reinforcement is not used and for Pullout Strength and Pryout Strength. Refer to your local standard.
- Refer to the manufacturer's product literature for cleaning and installation instructions.
- Checking the transfer of loads into the base material and the shear resistance are required in accordance with ACI 318 or the relevant standard!
- Hilti post-installed anchors shall be installed in accordance with the Hilti Manufacturer's Printed Installation Instructions (MPII). Reference ACI 318-14, Section 17.8.1.

Fastening meets the design criteria!

www.hilti.us

Company: CAE PIPING
 Specifier: SAM SALISSEN
 Address:
 Phone | Fax: |
 E-Mail:

Page: 6
 Project: ANCHOR BOLTS
 Sub-Project | Pos. No.:
 Date: 6/24/2019

7 Installation data

| | |
|--|---|
| Anchor plate, steel: - | Anchor type and diameter: Kwik Bolt TZ - CS 3/8 (2 3/4) |
| Profile: no profile | Installation torque: 25.000 ft.lb |
| Hole diameter in the fixture: $d_f = 0.438$ in. | Hole diameter in the base material: 0.375 in. |
| Plate thickness (input): 0.250 in. | Hole depth in the base material: 3.375 in. |
| Recommended plate thickness: not calculated | Minimum thickness of the base material: 5.000 in. |
| Drilling method: Hammer drilled | |
| Cleaning: Manual cleaning of the drilled hole according to instructions for use is required. | |

7.1 Recommended accessories

| Drilling | Cleaning | Setting |
|--|--|---|
| <ul style="list-style-type: none"> • Suitable Rotary Hammer • Properly sized drill bit | <ul style="list-style-type: none"> • Manual blow-out pump | <ul style="list-style-type: none"> • Torque wrench • Hammer |

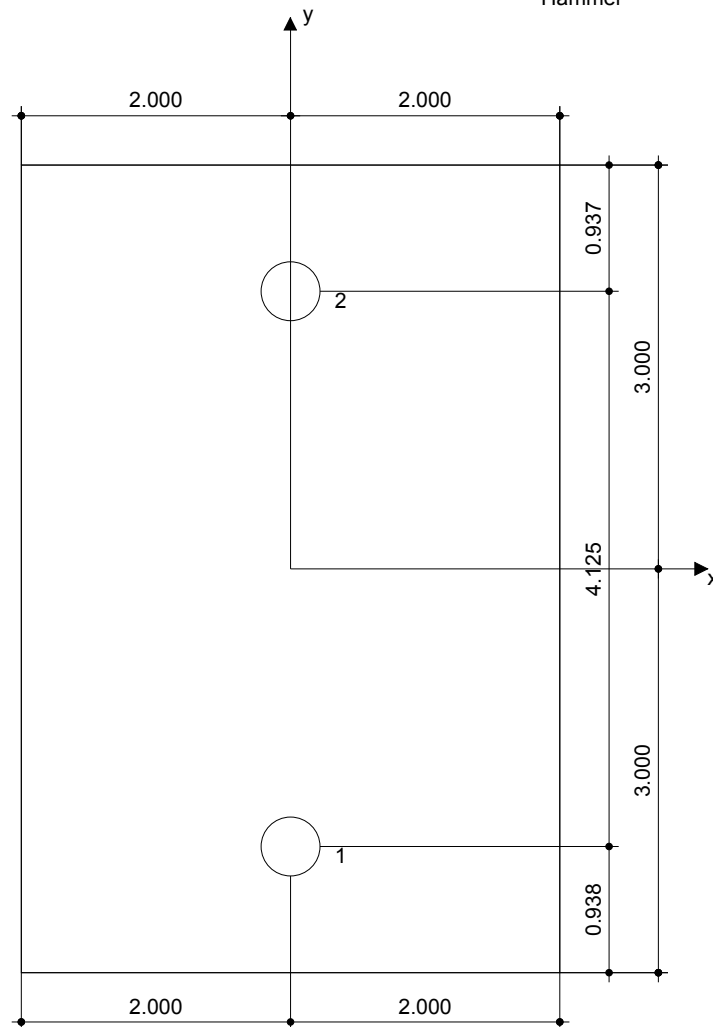

Coordinates Anchor in.

| Anchor | x | y | C-x | C+X | C-y | C+y |
|--------|-------|--------|--------|--------|--------|--------|
| 1 | 0.000 | -2.063 | 10.000 | 10.000 | 10.000 | 14.125 |
| 2 | 0.000 | 2.063 | 10.000 | 10.000 | 14.125 | 10.000 |

www.hilti.us

Company: CAE PIPING
Specifier: SAM SALISSEN
Address:
Phone | Fax: |
E-Mail:

Page: 7
Project: ANCHOR BOLTS
Sub-Project | Pos. No.:
Date: 6/24/2019

8 Remarks; Your Cooperation Duties

- Any and all information and data contained in the Software concern solely the use of Hilti products and are based on the principles, formulas and security regulations in accordance with Hilti's technical directions and operating, mounting and assembly instructions, etc., that must be strictly complied with by the user. All figures contained therein are average figures, and therefore use-specific tests are to be conducted prior to using the relevant Hilti product. The results of the calculations carried out by means of the Software are based essentially on the data you put in. Therefore, you bear the sole responsibility for the absence of errors, the completeness and the relevance of the data to be put in by you. Moreover, you bear sole responsibility for having the results of the calculation checked and cleared by an expert, particularly with regard to compliance with applicable norms and permits, prior to using them for your specific facility. The Software serves only as an aid to interpret norms and permits without any guarantee as to the absence of errors, the correctness and the relevance of the results or suitability for a specific application.
- You must take all necessary and reasonable steps to prevent or limit damage caused by the Software. In particular, you must arrange for the regular backup of programs and data and, if applicable, carry out the updates of the Software offered by Hilti on a regular basis. If you do not use the AutoUpdate function of the Software, you must ensure that you are using the current and thus up-to-date version of the Software in each case by carrying out manual updates via the Hilti Website. Hilti will not be liable for consequences, such as the recovery of lost or damaged data or programs, arising from a culpable breach of duty by you.

www.hilti.us

Company: CAE PIPING
 Specifier: SAM SALISSEN
 Address:
 Phone | Fax: |
 E-Mail:

Page: 1
 Project: SIDE ANCHOR BOLTS
 Sub-Project | Pos. No.:
 Date: 6/24/2019

Specifier's comments:
1 Input data

| | |
|----------------------------------|--|
| Anchor type and diameter: | Kwik Bolt TZ - CS 3/8 (2 3/4) |
| Effective embedment depth: | $h_{ef,act} = 2.750 \text{ in.}$, $h_{nom} = 3.063 \text{ in.}$ |
| Material: | Carbon Steel |
| Evaluation Service Report: | ESR-1917 |
| Issued Valid: | 6/1/2016 5/1/2017 |
| Proof: | Design method ACI 318-14 / Mech. |
| Stand-off installation: | - (Recommended plate thickness: not calculated) |
| Profile: | no profile |
| Base material: | cracked concrete, 2500, $f'_c = 2500 \text{ psi}$; $h = 5.000 \text{ in.}$ |
| Installation: | hammer drilled hole, Installation condition: Dry |
| Reinforcement: | tension: condition B, shear: condition B; no supplemental splitting reinforcement present edge reinforcement: none or < No. 4 bar |

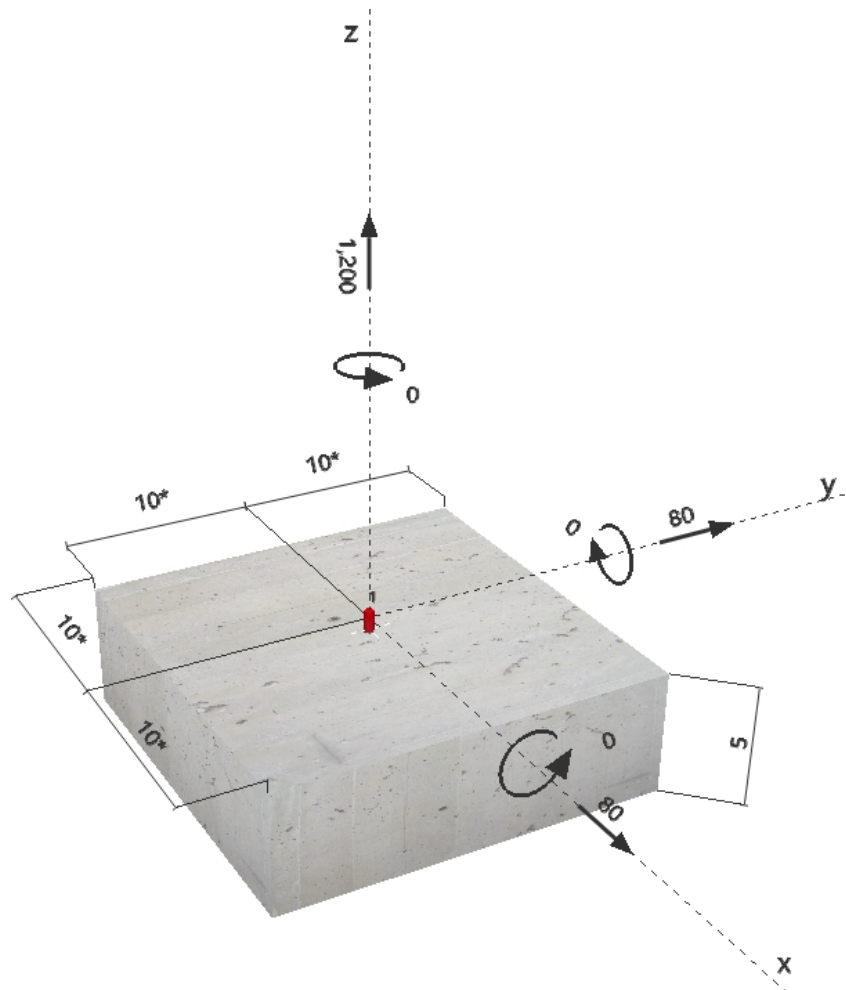
Geometry [in.] & Loading [lb, in.lb]

www.hilti.us

Company: CAE PIPING
 Specifier: SAM SALISSEN
 Address:
 Phone | Fax: |
 E-Mail:

Page: 2
 Project: SIDE ANCHOR BOLTS
 Sub-Project | Pos. No.:
 Date: 6/24/2019

2 Load case/Resulting anchor forces

Load case: Design loads

Anchor reactions [lb]

Tension force: (+Tension, -Compression)

| Anchor | Tension force | Shear force | Shear force x | Shear force y |
|--------|---------------|-------------|---------------|---------------|
| 1 | 1200 | 113 | 80 | 80 |

max. concrete compressive strain: - [‰]
 max. concrete compressive stress: - [psi]
 resulting tension force in (x/y)=(0.000/0.000): 0 [lb]
 resulting compression force in (x/y)=(0.000/0.000): 0 [lb]

3 Tension load

| | Load N_{ua} [lb] | Capacity ϕN_n [lb] | Utilization $\beta_N = N_{ua}/\phi N_n$ | Status |
|------------------------------|--------------------|--------------------------|---|--------|
| Steel Strength* | 1200 | 4875 | 25 | OK |
| Pullout Strength* | 1200 | 2051 | 59 | OK |
| Concrete Breakout Strength** | 1200 | 2520 | 48 | OK |

* anchor having the highest loading **anchor group (anchors in tension)

3.1 Steel Strength

N_{sa} = ESR value refer to ICC-ES ESR-1917
 $\phi N_{sa} \geq N_{ua}$ ACI 318-14 Table 17.3.1.1

Variables

| $A_{se,N}$ [in. ²] | f_{uta} [psi] |
|--------------------------------|-----------------|
| 0.05 | 125000 |

Calculations

| N_{sa} [lb] |
|---------------|
| 6500 |

Results

| N_{sa} [lb] | ϕ_{steel} | ϕN_{sa} [lb] | N_{ua} [lb] |
|---------------|----------------|--------------------|---------------|
| 6500 | 0.750 | 4875 | 1200 |

www.hilti.us

 Company: CAE PIPING
 Specifier: SAM SALISSEN
 Address:
 Phone | Fax: |
 E-Mail:

 Page: 3
 Project: SIDE ANCHOR BOLTS
 Sub-Project | Pos. No.:
 Date: 6/24/2019

3.2 Pullout Strength

$$N_{pn,f_c} = N_{p,2500} \lambda_a \sqrt{\frac{f_c}{2500}} \quad \text{refer to ICC-ES ESR-1917}$$

$$\phi N_{pn,f_c} \geq N_{ua} \quad \text{ACI 318-14 Table 17.3.1.1}$$

Variables

| f_c [psi] | λ_a | $N_{p,2500}$ [lb] |
|-------------|-------------|-------------------|
| 2500 | 1.000 | 3155 |

Calculations

$$\frac{\sqrt{\frac{f_c}{2500}}}{1.000}$$

Results

| N_{pn,f_c} [lb] | $\phi_{concrete}$ | $\phi N_{pn,f_c}$ [lb] | N_{ua} [lb] |
|-------------------|-------------------|------------------------|---------------|
| 3155 | 0.650 | 2051 | 1200 |

3.3 Concrete Breakout Strength

$$N_{cb} = \left(\frac{A_{Nc}}{A_{Nc0}} \right) \Psi_{ed,N} \Psi_{c,N} \Psi_{cp,N} N_b \quad \text{ACI 318-14 Eq. (17.4.2.1a)}$$

$$\phi N_{cb} \geq N_{ua} \quad \text{ACI 318-14 Table 17.3.1.1}$$

$$A_{Nc} \text{ see ACI 318-14, Section 17.4.2.1, Fig. R 17.4.2.1(b)}$$

$$A_{Nc0} = 9 h_{ef}^2 \quad \text{ACI 318-14 Eq. (17.4.2.1c)}$$

$$\Psi_{ec,N} = \left(\frac{1}{1 + \frac{2 e_N}{3 h_{ef}}} \right) \leq 1.0 \quad \text{ACI 318-14 Eq. (17.4.2.4)}$$

$$\Psi_{ed,N} = 0.7 + 0.3 \left(\frac{C_{a,min}}{1.5 h_{ef}} \right) \leq 1.0 \quad \text{ACI 318-14 Eq. (17.4.2.5b)}$$

$$\Psi_{cp,N} = \text{MAX} \left(\frac{C_{a,min}}{C_{ac}}, \frac{1.5 h_{ef}}{C_{ac}} \right) \leq 1.0 \quad \text{ACI 318-14 Eq. (17.4.2.7b)}$$

$$N_b = k_c \lambda_a \sqrt{f_c} h_{ef}^{1.5} \quad \text{ACI 318-14 Eq. (17.4.2.2a)}$$

Variables

| h_{ef} [in.] | $e_{c1,N}$ [in.] | $e_{c2,N}$ [in.] | $C_{a,min}$ [in.] | $\Psi_{c,N}$ |
|----------------|------------------|------------------|-------------------|--------------|
| 2.750 | 0.000 | 0.000 | 10.000 | 1.000 |

| C_{ac} [in.] | k_c | λ_a | f_c [psi] |
|----------------|-------|-------------|-------------|
| 4.125 | 17 | 1.000 | 2500 |

Calculations

| A_{Nc} [in. ²] | A_{Nc0} [in. ²] | $\Psi_{ec1,N}$ | $\Psi_{ec2,N}$ | $\Psi_{ed,N}$ | $\Psi_{cp,N}$ | N_b [lb] |
|------------------------------|-------------------------------|----------------|----------------|---------------|---------------|------------|
| 68.06 | 68.06 | 1.000 | 1.000 | 1.000 | 1.000 | 3876 |

Results

| N_{cb} [lb] | $\phi_{concrete}$ | ϕN_{cb} [lb] | N_{ua} [lb] |
|---------------|-------------------|--------------------|---------------|
| 3876 | 0.650 | 2520 | 1200 |

www.hilti.us

 Company: CAE PIPING
 Specifier: SAM SALISSEN
 Address:
 Phone | Fax: |
 E-Mail:

 Page: 4
 Project: SIDE ANCHOR BOLTS
 Sub-Project | Pos. No.:
 Date: 6/24/2019

4 Shear load

| | Load V_{ua} [lb] | Capacity ϕV_n [lb] | Utilization $\beta_V = V_{ua}/\phi V_n$ | Status |
|---|--------------------|--------------------------|---|--------|
| Steel Strength* | 113 | 2337 | 5 | OK |
| Steel failure (with lever arm)* | N/A | N/A | N/A | N/A |
| Pryout Strength** | 113 | 5427 | 3 | OK |
| Concrete edge failure in direction x+** | 113 | 2720 | 5 | OK |

* anchor having the highest loading **anchor group (relevant anchors)

4.1 Steel Strength

 V_{sa} = ESR value refer to ICC-ES ESR-1917
 $\phi V_{steel} \geq V_{ua}$ ACI 318-14 Table 17.3.1.1

Variables

| | |
|--------------------------------|-----------------|
| $A_{se,V}$ [in. ²] | f_{uta} [psi] |
| 0.05 | 125000 |

Calculations

| |
|---------------|
| V_{sa} [lb] |
| 3595 |

Results

| | | | |
|---------------|----------------|--------------------|---------------|
| V_{sa} [lb] | ϕ_{steel} | ϕV_{sa} [lb] | V_{ua} [lb] |
| 3595 | 0.650 | 2337 | 113 |

4.2 Pryout Strength

$$V_{cp} = k_{cp} \left[\left(\frac{A_{Nc}}{A_{Nc0}} \right) \Psi_{ed,N} \Psi_{c,N} \Psi_{cp,N} N_b \right] \quad \text{ACI 318-14 Eq. (17.5.3.1a)}$$

$$\phi V_{cp} \geq V_{ua} \quad \text{ACI 318-14 Table 17.3.1.1}$$

$$A_{Nc} \text{ see ACI 318-14, Section 17.4.2.1, Fig. R 17.4.2.1(b)}$$

$$A_{Nc0} = 9 h_{ef}^2 \quad \text{ACI 318-14 Eq. (17.4.2.1c)}$$

$$\Psi_{ec,N} = \left(\frac{1}{1 + \frac{2 e_N}{3 h_{ef}}} \right) \leq 1.0 \quad \text{ACI 318-14 Eq. (17.4.2.4)}$$

$$\Psi_{ed,N} = 0.7 + 0.3 \left(\frac{c_{a,min}}{1.5 h_{ef}} \right) \leq 1.0 \quad \text{ACI 318-14 Eq. (17.4.2.5b)}$$

$$\Psi_{cp,N} = \text{MAX} \left(\frac{c_{a,min}}{c_{ac}}, \frac{1.5 h_{ef}}{c_{ac}} \right) \leq 1.0 \quad \text{ACI 318-14 Eq. (17.4.2.7b)}$$

$$N_b = k_c \lambda_a \sqrt{f'_c} h_{ef}^{1.5} \quad \text{ACI 318-14 Eq. (17.4.2.2a)}$$

Variables

| | | | | |
|--------------|----------------|------------------|------------------|-------------------|
| k_{cp} | h_{ef} [in.] | $e_{c1,N}$ [in.] | $e_{c2,N}$ [in.] | $c_{a,min}$ [in.] |
| 2 | 2.750 | 0.000 | 0.000 | 10.000 |
| $\Psi_{c,N}$ | c_{ac} [in.] | k_c | λ_a | f'_c [psi] |
| 1.000 | 4.125 | 17 | 1.000 | 2500 |

Calculations

| | | | | | | |
|------------------------------|-------------------------------|----------------|----------------|---------------|---------------|------------|
| A_{Nc} [in. ²] | A_{Nc0} [in. ²] | $\Psi_{ec1,N}$ | $\Psi_{ec2,N}$ | $\Psi_{ed,N}$ | $\Psi_{cp,N}$ | N_b [lb] |
| 68.06 | 68.06 | 1.000 | 1.000 | 1.000 | 1.000 | 3876 |

Results

| | | | |
|---------------|-------------------|--------------------|---------------|
| V_{cp} [lb] | $\phi_{concrete}$ | ϕV_{cp} [lb] | V_{ua} [lb] |
| 7753 | 0.700 | 5427 | 113 |

www.hilti.us

Company: CAE PIPING
 Specifier: SAM SALISSEN
 Address:
 Phone | Fax: |
 E-Mail:

Page: 5
 Project: SIDE ANCHOR BOLTS
 Sub-Project | Pos. No.:
 Date: 6/24/2019

4.3 Concrete edge failure in direction x+

$$V_{cb} = \left(\frac{A_{Vc}}{A_{Vc0}} \right) \psi_{ed,V} \psi_{c,V} \psi_{h,V} \psi_{parallel,V} V_b \quad \text{ACI 318-14 Eq. (17.5.2.1a)}$$

$$\phi V_{cb} \geq V_{ua} \quad \text{ACI 318-14 Table 17.3.1.1}$$

A_{Vc} see ACI 318-14, Section 17.5.2.1, Fig. R 17.5.2.1(b)

$$A_{Vc0} = 4.5 c_{a1}^2 \quad \text{ACI 318-14 Eq. (17.5.2.1c)}$$

$$\psi_{ec,V} = \left(\frac{1}{1 + \frac{2e_v}{3c_{a1}}} \right) \leq 1.0 \quad \text{ACI 318-14 Eq. (17.5.2.5)}$$

$$\psi_{ed,V} = 0.7 + 0.3 \left(\frac{c_{a2}}{1.5c_{a1}} \right) \leq 1.0 \quad \text{ACI 318-14 Eq. (17.5.2.6b)}$$

$$\psi_{h,V} = \sqrt{\frac{1.5c_{a1}}{h_a}} \geq 1.0 \quad \text{ACI 318-14 Eq. (17.5.2.8)}$$

$$V_b = \left(7 \left(\frac{l_e}{d_a} \right)^{0.2} \sqrt{d_a} \right) \lambda_a \sqrt{f_c} c_{a1}^{1.5} \quad \text{ACI 318-14 Eq. (17.5.2.2a)}$$

Variables

| c_{a1} [in.] | c_{a2} [in.] | e_{cV} [in.] | $\psi_{c,V}$ | h_a [in.] |
|----------------|----------------|----------------|--------------|---------------------|
| 6.667 | 10.000 | 0.000 | 1.000 | 5.000 |
| l_e [in.] | λ_a | d_a [in.] | f_c [psi] | $\psi_{parallel,V}$ |
| 2.750 | 1.000 | 0.375 | 2500 | 1.000 |

Calculations

| A_{Vc} [in. ²] | A_{Vc0} [in. ²] | $\psi_{ec,V}$ | $\psi_{ed,V}$ | $\psi_{h,V}$ | V_b [lb] |
|------------------------------|-------------------------------|---------------|---------------|--------------|------------|
| 100.00 | 200.00 | 1.000 | 1.000 | 1.414 | 5495 |

Results

| V_{cb} [lb] | $\phi_{concrete}$ | ϕV_{cb} [lb] | V_{ua} [lb] |
|---------------|-------------------|--------------------|---------------|
| 3886 | 0.700 | 2720 | 113 |

5 Combined tension and shear loads

| β_N | β_V | ζ | Utilization $\beta_{N,V}$ [%] | Status |
|-----------|-----------|---------|-------------------------------|--------|
| 0.585 | 0.048 | 5/3 | 42 | OK |

$$\beta_{NV} = \beta_N^\zeta + \beta_V^\zeta \leq 1$$

6 Warnings

- Load re-distributions on the anchors due to elastic deformations of the anchor plate are not considered. The anchor plate is assumed to be sufficiently stiff, in order not to be deformed when subjected to the loading! Input data and results must be checked for agreement with the existing conditions and for plausibility!
- Condition A applies when supplementary reinforcement is used. The Φ factor is increased for non-steel Design Strengths except Pullout Strength and Pryout strength. Condition B applies when supplementary reinforcement is not used and for Pullout Strength and Pryout Strength. Refer to your local standard.
- Refer to the manufacturer's product literature for cleaning and installation instructions.
- Checking the transfer of loads into the base material and the shear resistance are required in accordance with ACI 318 or the relevant standard!
- Hilti post-installed anchors shall be installed in accordance with the Hilti Manufacturer's Printed Installation Instructions (MPII). Reference ACI 318-14, Section 17.8.1.

Fastening meets the design criteria!

www.hilti.us

Company: CAE PIPING
Specifier: SAM SALISSEN
Address:
Phone | Fax: |
E-Mail:

Page: 6
Project: SIDE ANCHOR BOLTS
Sub-Project | Pos. No.:
Date: 6/24/2019

7 Installation data

Anchor plate, steel: -
Profile: -
Hole diameter in the fixture: -
Plate thickness (input): -
Recommended plate thickness: -
Drilling method: Hammer drilled
Cleaning: Manual cleaning of the drilled hole according to instructions for use is required.

Anchor type and diameter: Kwik Bolt TZ - CS 3/8 (2 3/4)
Installation torque: 300.000 in.lb
Hole diameter in the base material: 0.375 in.
Hole depth in the base material: 3.375 in.
Minimum thickness of the base material: 5.000 in.

7.1 Recommended accessories

| Drilling | Cleaning | Setting |
|---|--|--|
| <ul style="list-style-type: none">Suitable Rotary HammerProperly sized drill bit | <ul style="list-style-type: none">Manual blow-out pump | <ul style="list-style-type: none">Torque wrenchHammer |

Coordinates Anchor in.

| Anchor | x | y | C-x | C+x | C-y | C+y |
|--------|-------|-------|--------|--------|--------|--------|
| 1 | 0.000 | 0.000 | 10.000 | 10.000 | 10.000 | 10.000 |

8 Remarks; Your Cooperation Duties

- Any and all information and data contained in the Software concern solely the use of Hilti products and are based on the principles, formulas and security regulations in accordance with Hilti's technical directions and operating, mounting and assembly instructions, etc., that must be strictly complied with by the user. All figures contained therein are average figures, and therefore use-specific tests are to be conducted prior to using the relevant Hilti product. The results of the calculations carried out by means of the Software are based essentially on the data you put in. Therefore, you bear the sole responsibility for the absence of errors, the completeness and the relevance of the data to be put in by you. Moreover, you bear sole responsibility for having the results of the calculation checked and cleared by an expert, particularly with regard to compliance with applicable norms and permits, prior to using them for your specific facility. The Software serves only as an aid to interpret norms and permits without any guarantee as to the absence of errors, the correctness and the relevance of the results or suitability for a specific application.
- You must take all necessary and reasonable steps to prevent or limit damage caused by the Software. In particular, you must arrange for the regular backup of programs and data and, if applicable, carry out the updates of the Software offered by Hilti on a regular basis. If you do not use the AutoUpdate function of the Software, you must ensure that you are using the current and thus up-to-date version of the Software in each case by carrying out manual updates via the Hilti Website. Hilti will not be liable for consequences, such as the recovery of lost or damaged data or programs, arising from a culpable breach of duty by you.