



NOTICE
Series
Identification

Read the boiler rating label to determine the series number. The rating label is located on the right side of the boiler (inside).

Heat Exchanger Replacement Instructions

Kit part numbers 383-600-215, 383-600-216 & 383-600-217

SlimFit model numbers:

Left-hand boilers

(cleanout access on left side when facing burner end)

SF1000L — 1000 MBH input

SF1500L — 1500 MBH input

SF2000L — 2000 MBH input

Right-hand boilers

(cleanout access on right side when facing burner end)

SF1000R — 1000 MBH input

SF1500R — 1500 MBH input

SF2000R — 2000 MBH input

STOP! Read before proceeding

Hazard definitions

The following defined terms are used throughout this manual to bring attention to the presence of hazards of various risk levels or to important information concerning the life of the product.

▲ DANGER Indicates presence of hazards that will cause severe personal injury, death or substantial property damage.

▲ WARNING Indicates presence of hazards that can cause severe personal injury, death or substantial property damage.

▲ CAUTION Indicates presence of hazards that will or can cause minor personal injury or property damage.

NOTICE Indicates special instructions on installation, operation or maintenance that are important but not related to personal injury or property damage.

▲ WARNING **These instructions must only be used by a qualified installer/service technician.** Read all instructions completely before beginning the installation. Failure to follow all instructions can cause severe personal injury, death or substantial property damage.



You must read and have the **SlimFit™** Boiler Manual with you to proceed with these instructions.

The Boiler Manual is available online at Weil-McLain.com



The SlimFit™ Commercial Condensing Water Boiler (Model SF1000 shown)

SlimFit model numbers:

Left-hand boilers (cleanout access on left side when facing burner end)

SF1000L — 1000 MBH input
SF1500L — 1500 MBH input
SF2000L — 2000 MBH input

Right-hand boilers (cleanout access on right side when facing burner end)

SF1000R — 1000 MBH input
SF1500R — 1500 MBH input
SF2000R — 2000 MBH input

1 Cast aluminum sectional heat exchanger

Heat exchanger can be supplied in left-hand or right-hand configuration. They CANNOT be field converted. They must be purchased as right or left.

Left-hand configuration — cleanout access and gas pipe on left side; supply and return pipes on right side.

Right-hand configuration — cleanout access and gas pipe on right side; supply and return pipes on left side.

2 Heat exchanger cleanout plate

3 Blower

Air enters through the air intake adapter, then enters the venturi. The blower pulls air and gas through the venturi and pushes the mixture into the burner. The advanced blower design and air inlet silencer yield very quiet operation.

4 Blower motor

5 Venturi

When air flows through the venturi, it creates a vacuum that is sensed by the gas valve to regulate gas flow.

6 Acoustic adapter (Model SF1000 only)

This adapter includes an acoustic chamber that minimizes combustion noise.

7 Sola control module

The Sola control module responds to inputs from system heating or DHW controls (or building management system), boiler sensors (boiler return, boiler supply, heat exchanger, system return, system supply, flue temperature, and outdoor temperature, if used). The control module automatically adjusts blower speed (and gas flow rate) to match boiler output to space heating and/or DHW heating demand.

The Sola control module includes versatile programmability, allowing for: Operation of boiler pump, DHW pump, system pump and others.

Lead/lag regulation of multiple SlimFit boilers.

Priority regulation for DHW, space heating or other loads.

8 Sola touch-screen LCD display

The color display provides graphics and multi-line text display. Information and programming functions are accessed via touch-screen navigation.

See configuration options on page 3 for orientation options.

9 Automatic gas valve

The automatic gas valve incorporates two solenoid-operated valve seats. The valve senses the vacuum in the venturi (item 5) caused by flowing air. Gas flows in proportion to air flow, so fuel/air ratio remains constant as blower speed/air flow changes.

10 Gas valve reference line

This line is used to measure the pressure of the incoming air to the venturi and adjust the combustion accordingly.

11 Electrical entrance snap-in covers

Knockouts are provided in the jacket top panel, allowing conduit entry above the low-voltage and line-voltage field wiring terminal strips.

12 Gas valve test cock

13 Terminal strips

14 ON/OFF switch

15 Reset switch

16 Blower relay

17 Minimum air flow relay

18 Transformer

19 Spark generator

20 High gas pressure switch

21 Low gas pressure switch

22 Flue pressure switch

23 Minimum air flow switch

24 Low water cutoff circuit board

25 Low water cutoff test switch

26 Low water cutoff reset switch

27 Low water cutoff probe (not shown)

The low water cutoff probe is mounted in a tapping in the right top corner of the burner end section.

28 Premix gas burner (not shown)

Made with high-grade stainless steel and fiber mesh construction, the burner uses pre-mixed air and gas. The burner and control provide modulating firing.

29 Ignition electrode and flame sensor (not shown)

The burner flame is ignited by applying a high voltage to the ignition electrode, located in the front section. This causes a spark (from electrode to ground). After ignition, the flame sensor electrode (not shown, located in the rear section) measures flame signal.

30 Flame inspection window

The quartz glass windows provides a view of the burner surface and flame (one located on each boiler end section).

31 Water outlet pipe (system supply) — 3" flanged

32 Water return pipe (system return) — 3" flanged

33 Gauge tapping

The pressure/temperature gauge is shipped loose for field installation in this tapping.

34 Relief valve tapping

The relief valve is shipped loose for field installation in this tapping.

35 Temperature sensor tapping — outlet temperature (not visible in the view shown)

The outlet sensor tapping is located on top of the outlet pipe, just outside the heat exchanger connection.

36 Temperature sensor tapping — return temperature (not visible in the view shown)

The return sensor tapping is located on top of the return pipe, just outside the heat exchanger connection.

37 Gas connection

38 Vent connection

Vent pipe connection, 10-inch nominal (9.85" I.D.). Installer must provide a vent/air pipe manufacturer's SlimFit Vent/Air Adapter to adapt to the vent pipe used. Where the manual allows vent pipe smaller than the adapter outlet, a reducer must also be provided by the installer.

39 Air intake connection

Air pipe connection, 10-inch nominal (9.85" I.D.). Installer must provide a vent/air pipe manufacturer's SlimFit Vent/Air Adapter to adapt to the air pipe used. Where the manual allows vent pipe smaller than the adapter outlet, a reducer must also be provided by the installer. Leave air connection open for inside air applications (direct exhaust).

40 Condensate trap assembly

41 Burner end access doors

The three access panels on the burner end are interchangeable. This allows location of the Sola display on either the front side or burner end of the boiler.

42 Piping end access doors

The three access panels on the piping end are removable for access and servicing.

43 Electrical access panel

44 Casters (used for locating boiler only)

45 Mounting legs (extended after boiler is in position)



The **SlimFit™** Commercial Condensing Water Boiler (Model SF1000 shown)

Configuration options

(Order boiler as left-hand or right-hand)

Left-hand (suffix L)

- Cleanout panel access is on the left side when viewed from the burner end.
- Control display is factory-mounted on front (cleanout access side), but can be field relocated on burner end as instructed in this manual.



Right-hand (suffix R)

- Cleanout panel access is on the right side when viewed from the burner end.
- Control display is factory-mounted on front (cleanout access side), but can be field relocated on burner end as instructed in this manual.



Electrical panel components

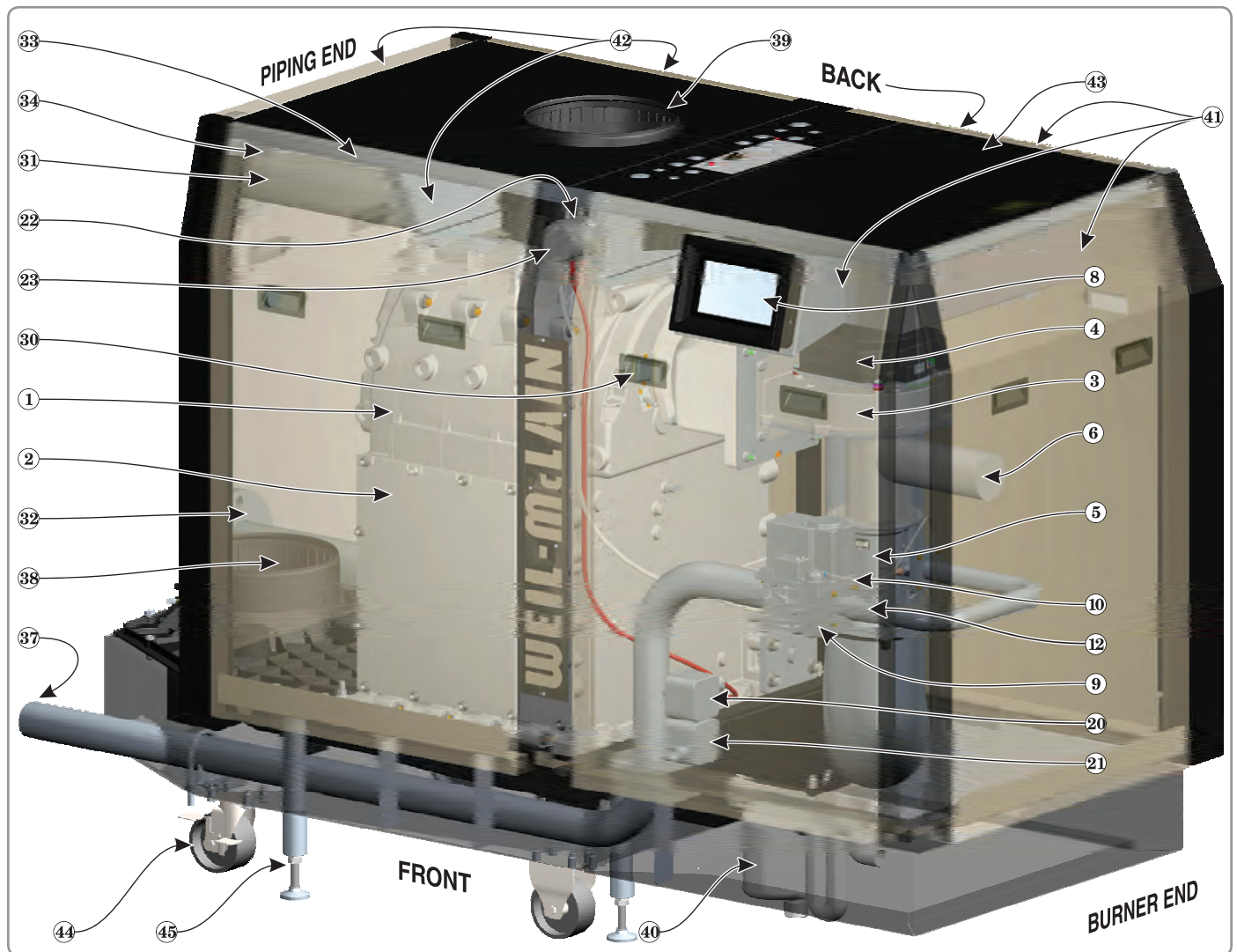
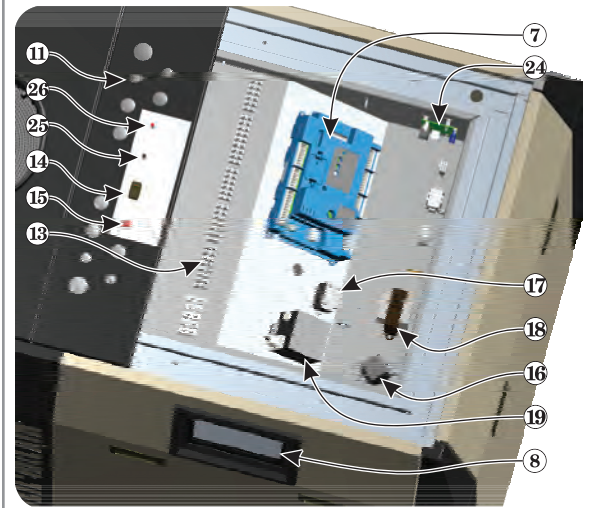



Kit part numbers 383-600-215, 383-600-216 & 383-600-217

P/N 383-600-215 Kit contents

Item	Description	Part No.	Qty
1	Sub Assembly Section-Block-5 SlimFit	323-600-007	1
2	Bag Assembly Hardware Section-Block-5 SlimFit	540-130-070	1
	Above hardware bag consist of the following:		
	Stud-Double End M10-1.5x62 DIN939 ZP	560-340-599	4
	Bolt Hex M8-1.25x22mm DIN 933 ZP	561-704-535	1
	Nut Hex Flange W/Nylon Insert M10-1.50 ZP	561-928-463	4
	Nut Hex Flange Top Lock M12x1.75ZP DIN 6927	561-928-473	30
	Screw Hex Cap M8-1.25x35mm ZP	562-135-771	2
	Washer M8 20mm OD x 2.0mm Thick ZP	562-248-761	3
	Gasket Burner Opening 7.88x.12x8.32	590-300-051	2
3	Silicone cord, 10mm x 150"	590-300-042	1
4	Instructions Heat Exchanger Repl. SlimFit	550-100-121	1

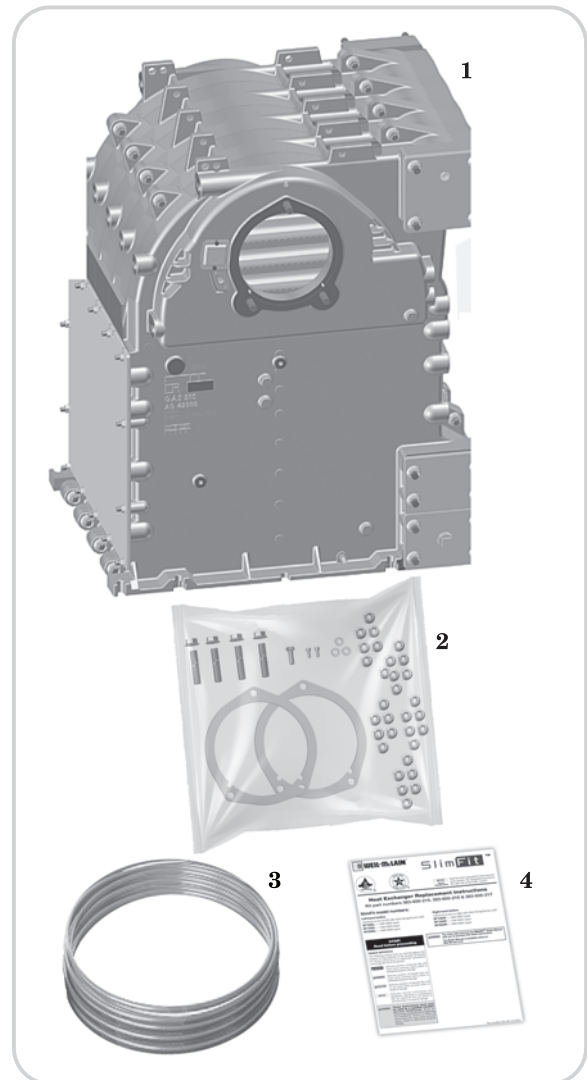

P/N 383-600-216 Kit contents

Item	Description	Part No.	Qty
1	Sub Assembly Section-Block-7 SlimFit	323-600-008	1
2	Bag Assembly Hardware Section-Block-7 SlimFit	540-130-071	1
	Above hardware bag consist of the following:		
	Stud-Double End M10-1.5x62 DIN939 ZP	560-340-599	4
	Bolt Hex M8-1.25x22mm DIN 933 ZP	561-704-535	1
	Nut Hex Flange W/Nylon Insert M10-1.50 ZP	561-928-463	4
	Nut Hex Flange Top Lock M12x1.75ZP DIN 6927	561-928-473	30
	Screw Hex Cap M8-1.25x35mm ZP	562-135-771	2
	Washer M8 20mm OD x 2.0mm Thick ZP	562-248-761	3
	Gasket Burner Opening 7.88x.12x8.32	590-300-051	2
3	Silicone cord, 10mm x 150"	590-300-042	1
4	Instructions Heat Exchanger Repl. SlimFit	550-100-121	1

P/N 383-600-217 Kit contents

Item	Description	Part No.	Qty
1	Sub Assembly Section-Block-9 SlimFit	323-600-009	1
2	Bag Assembly Hardware Section-Block-9 SlimFit	540-130-072	1
	Above hardware bag consist of the following:		
	Stud-Double End M10-1.5x62 DIN939 ZP	560-340-599	4
	Bolt Hex M8-1.25x22mm DIN 933 ZP	561-704-535	1
	Nut Hex Flange W/Nylon Insert M10-1.50 ZP	561-928-463	4
	Nut Hex Flange Top Lock M12x1.75ZP DIN 6927	561-928-473	30
	Screw Hex Cap M8-1.25x35mm ZP	562-135-771	2
	Washer M8 20mm OD x 2.0mm Thick ZP	562-248-761	3
	Gasket Burner Opening 7.88x.12x8.32	590-300-051	2
3	Silicone cord, 10mm x 150"	590-300-042	1
4	Instructions Heat Exchanger Repl. SlimFit	550-100-121	1



STOP!
Read before proceeding

▲WARNING The boiler contains ceramic fiber and fiberglass materials. Use care when handling these materials per instructions in the Boiler Manual, available on-line at Weil-McLain.com. Failure to comply could result in severe personal injury.

▲WARNING **Shut off power to the boiler and close main gas valve. Close all isolation valves.** Failure to do so can result in severe personal injury, death or substantial property damage.

▲WARNING **Wait for the heat exchanger to cool down before proceeding.** Failure to do so can result in severe personal injury.

▲WARNING Removing and reinstalling components can change boiler behavior. After any maintenance procedure, you must prove the boiler is operating correctly. To do so, **follow the complete procedure for boiler and system start-up as instructed in the Boiler Manual.** Failure to comply could result in severe personal injury, death or substantial property damage.

▲WARNING For component location reference, see previous pages. This is duplicated from the SlimFit Boiler manual, but included here for convenience. All instructions in the Boiler manual must be followed, including fuel requirements, water requirements and start-up/operation.

Recommended tools

Hoist capable of lifting the following weight: SF1000L/SF1000R: 865 pounds SF1500L/SF1500R: 1,050 pounds SF2000L/SF2000R: 1,250 pounds	
No. 2 Phillips head screwdriver, stubby	Pipe wrenches
Socket wrench or hex nut driver in the following sizes: 7mm, 8mm, 10mm, 13mm, 17mm, 5/16"	4mm Allen wrench
Torque wrench for inch-pounds	Torx driver, #25

Clearance requirements

This procedure requires adequate clearance to do the following:

- Remove all access doors.
- Access internal components from all sides, remove components and set aside in a clean staging area.
- Slide water supply pipe and water return pipe off of M12 mounting studs.
- Move hoisting system into place and stage both old heat exchanger and replacement heat exchanger.
- Perform hydrostatic test on replacement heat exchanger.

It is assumed that the boiler will need to be moved to an area that meets these clearance requirements. All necessary steps are included in these instructions.

Isolate the boiler

1. See **Figure 1** for the following:
2. Shut off power to the boiler.
3. Shut off the flow of gas to the boiler.
4. Shut off the flow of water to the water supply pipe (item 4).
5. Shut off the flow of water from the water return pipe (item 5).

Figure 1 Typical boiler connections (all external components, wiring and piping shown for reference only)

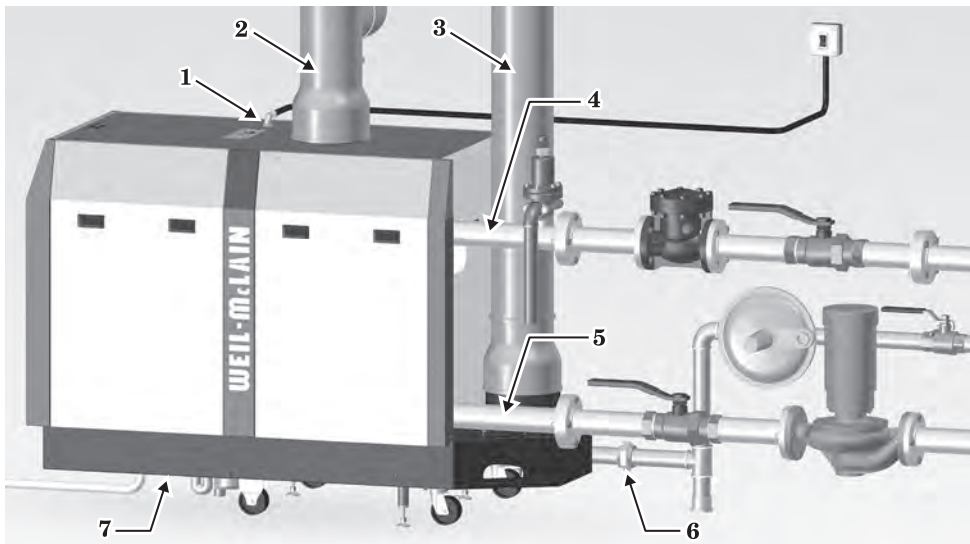

- 1 Electric entrance
- 2 Air pipe (air intake)
- 3 Air vent (vent connection)
- 4 Water outlet pipe (system supply)
- 5 Water return pipe (system return)
- 6 Gas connection
- 7 Condensate trap assembly



Remove all access doors and jacket posts for access to internal components

1. See **Figure 2** for the following:
2. Remove the front access door and four (4) side access doors by lifting up and away from boiler. Set aside.
3. Remove two (2) jacket side posts by lifting up until flanges clear slots in jacket top and bottom frame, then away from boiler (not shown). Set aside.
4. Remove the rear access door by lifting up, straight away from boiler, then to the side. Set aside.
5. Use a 5/16" nut driver to remove the two (2) screws (item 1) connecting each of the four (4) jacket corner posts to the jacket top frame. Set aside screws.
6. Remove jacket corner posts by lifting up and away. Set aside.

Figure 2 Remove access doors and posts.

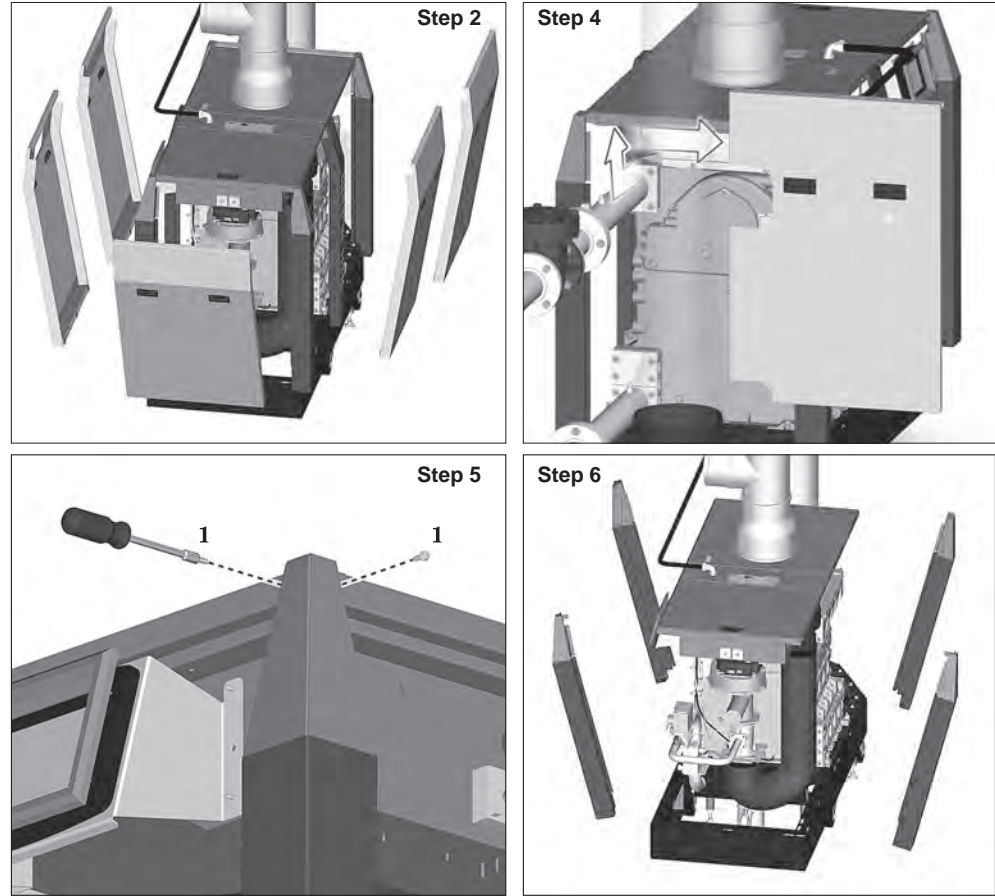

Drain heat exchanger

1. Allow the boiler to cool down completely before proceeding.

⚠WARNING Wait for the heat exchanger to cool down before draining. Failure to do so can result in severe personal injury.

2. Drain boiler through drain valve in return piping or through tapping at the lower right burner end of the heat exchanger.

Disconnect external piping and wires so boiler can move freely

1. Disconnect the gas supply piping at union.

⚠WARNING Use two (2) pipe wrenches when disconnecting the gas line to prevent damage to the piping or gas line components.

2. Disconnect field wiring from terminal strips and remove 120 VAC power supply from electrical entrance.
3. Disconnect the condensate trap assembly from drain piping or condensate pump.
4. See **Figure 3** for the following:
5. Remove the four hex nuts and bolts securing external piping to water supply pipe (item 2) and water return pipe (item 3). Set aside bolts and hex nuts.

Figure 3 Disconnect water supply and water return pipe from external piping (external components shown for reference only).

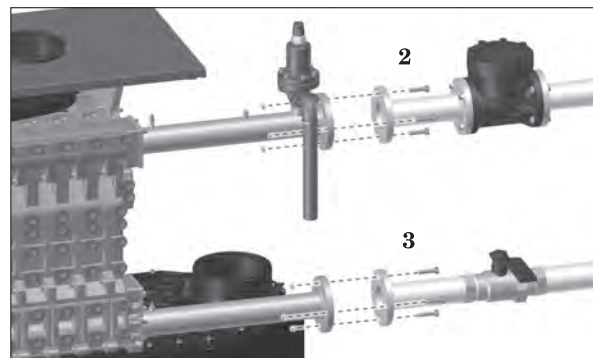

6. See **Figure 4** for the following:
7. Disconnect air piping from air intake (item 4), and vent piping from vent connection (item 5), by rotating the pipe to loosen, then lifting until piping is free of connection.

Figure 4 Disconnect air piping and vent piping by twisting and lifting.

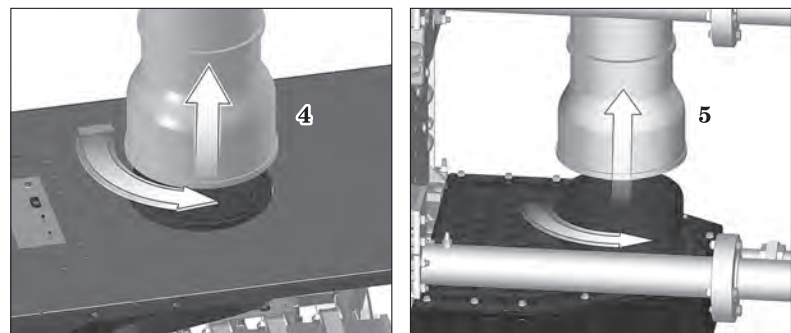

Move the boiler to an area with adequate clearance.

NOTICE If the boiler is mounted on mounting blocks, it will be necessary to locate and reinstall the original casters.

1. See **Figure 5** for the following:
2. Adjust the four (4) leveling legs upward until the four (4) casters can move freely.
3. The piping end casters are swivel type. The burner end casters are fixed.
4. Refer to page 5 for clearance requirements. Roll the boiler to a location with adequate clearance.
5. Adjust the leveling legs down until the casters are clear of the floor and the bottom of the boiler base is 5-1/4 inches above the floor.

Remove components for access to heat exchanger — disconnect and remove jacket top frame

1. See **Figure 6** for the following:
2. Pull the air flow switch tube (white hose, item 1) off the hose barb on the venturi.
3. Pull the flue pressure switch reference line (black hose, item 2) off the hose barb on the bottom burner end of the heat exchanger.
4. See **Figure 7** on the next page for the following:
5. Disconnect the 4-pin wire harness (item 3) to the automatic gas valve and the 6-pin wire harness (item 4) to the gas pressure switches.
6. Disconnect the two (2) wiring harnesses (items 5 & 6) from the back of the blower motor.
7. Disconnect the ignitor plug (item 7) and the red two-pronged thermal heat switch plug (item 9), both located at the burner end of the heat exchanger.
8. Twist to loosen and remove the block temperature switch (item 8).
9. **Save block temperature switch for reuse.**
10. Use a Phillips head screwdriver to remove the two (2) screws and lock washer holding the ignitor (item 11) in place. Remove the green grounding wire (item 10) and gasket.
11. **Save ignitor, screws, lock washer and gasket for reuse.**
12. Use a 5/16" socket wrench to remove the nut at the end of the low water cutoff probe (item 13), located on the water supply plate on the burner end of the heat exchanger, and remove the ring connector (item 12) (air inlet hose and air inlet box ghosted in illustration for clarity).
13. Use a 10mm socket wrench to loosen and remove the low water cutoff probe (item 13).
14. **Save low water cutoff probe and nut for reuse.**
15. Disconnect the flame sensor plug (item 16) located on the piping end of the heat exchanger.
16. Use a Phillips head screwdriver to remove the two (2) screws and lock washer holding the flame sensor (item 14) in place. Remove the green grounding wire (item 15) and gasket.
17. **Save sensor, screws, lock washer and gasket for reuse.**

Figure 5 Lift leveling legs to allow casters to move freely. Lower legs when boiler is in position for removal of heat exchanger.

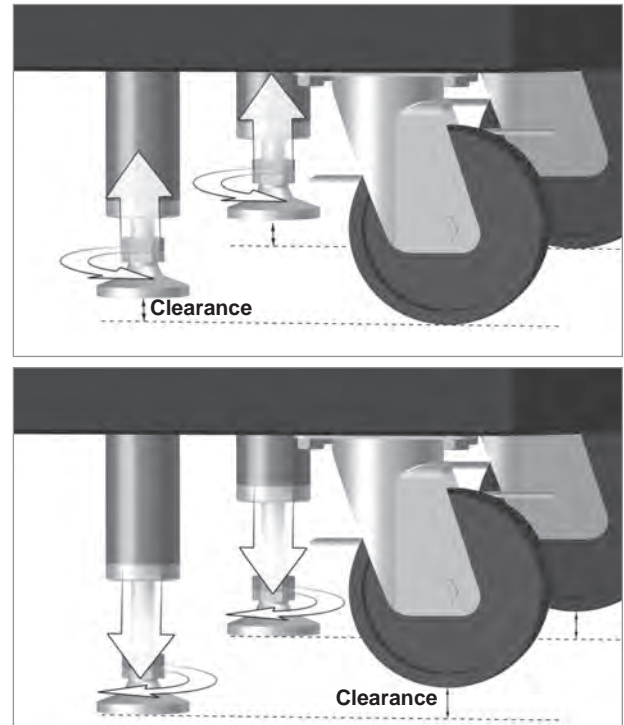

Figure 6 Disconnect white hose from venturi and black hose from heat exchanger.

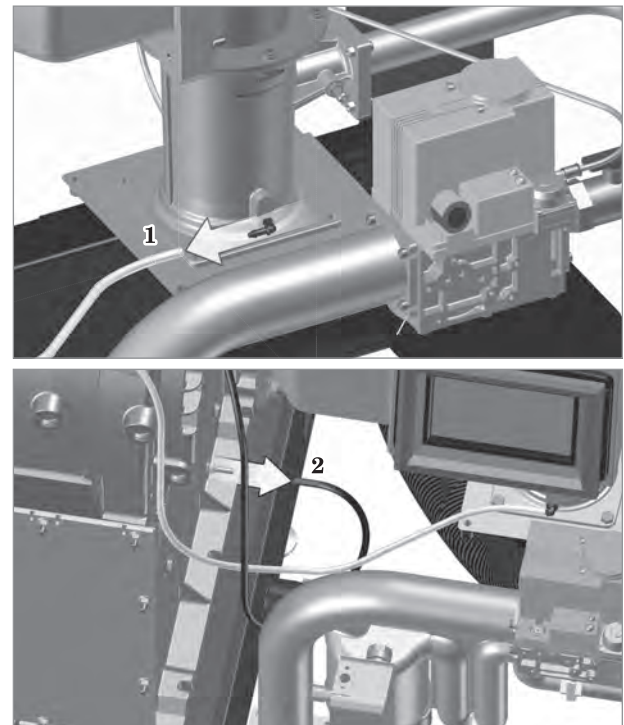
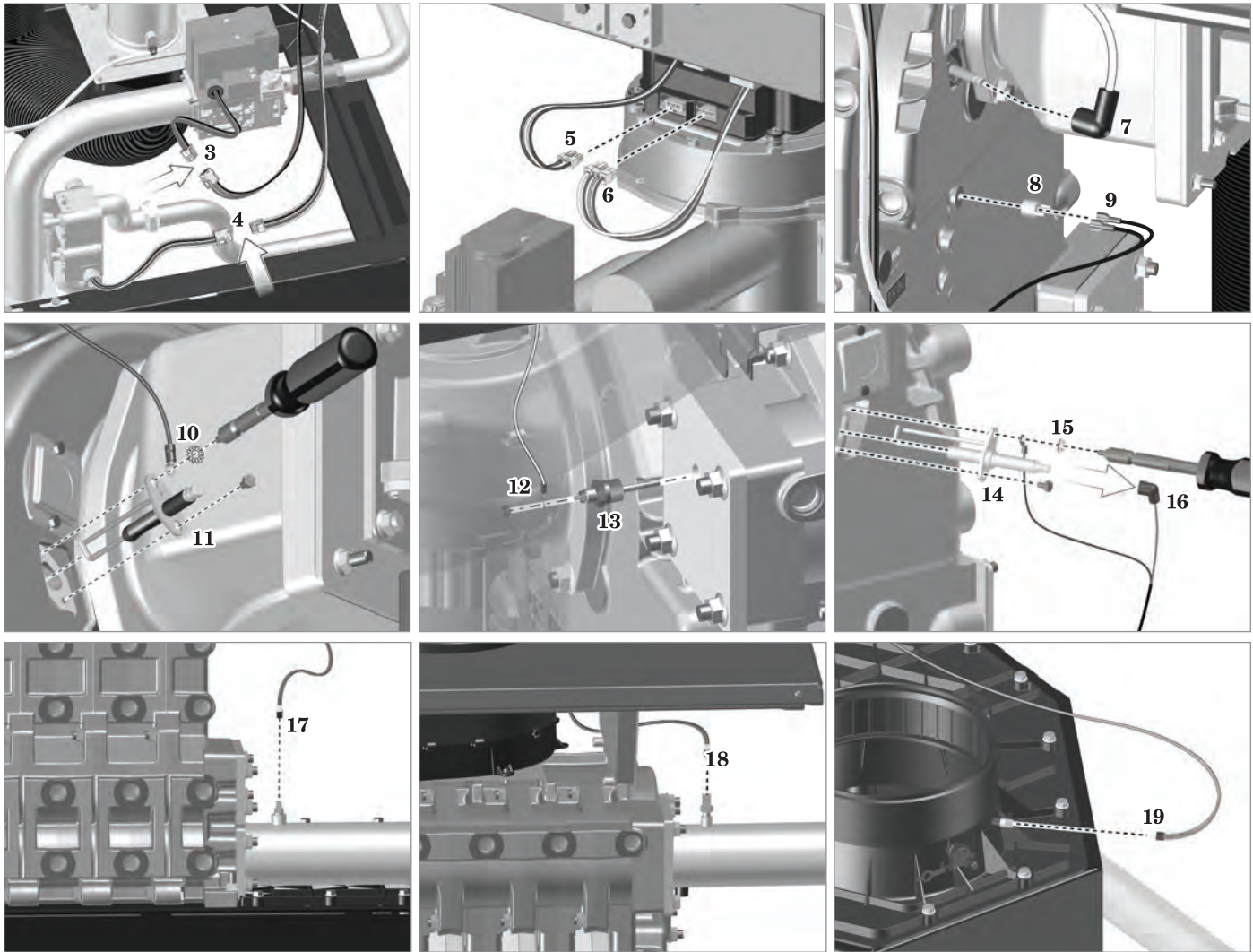
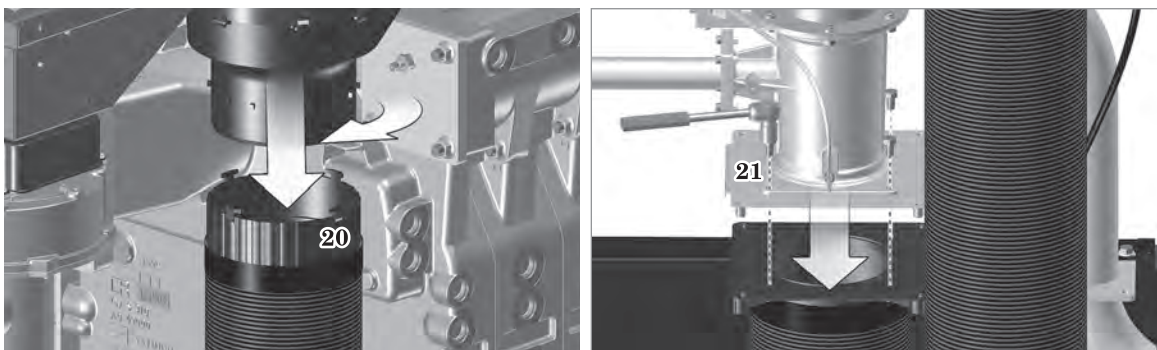

Figure 7 Disconnect all wires that are attached to the jacket top frame.



18. Unplug the return temperature sensor plug (item 17) located on the water return pipe.
19. Unplug the supply temperature sensor plug (item 18) located on the water supply pipe.
20. Unplug the flue temperature sensor plug (item 19) located on the vent connector.
21. See **Figure 8** for the following:
22. Disconnect the air inlet hose from the air inlet box (item 20) by rotating and pulling down.
23. Disconnect the air inlet hose from the venturi.
 - a. SF1000/SF1500: use an 8mm socket wrench to remove the four (4) M5 flange bolts (item 21). Set aside bolts.
 - b. SF2000: use a 13mm socket wrench to remove the four (4) M8 flange bolts (item 21). Set aside bolts.
24. Support the air inlet hose as the last bolt is removed. Slide out air inlet hose and set aside.

Figure 8 Disconnect both ends of air inlet hose and remove from boiler.





25. See **Figure 9** for the following.
26. Remove one (1) screw holding the electric access panel, then remove electric access panel from the jacket top frame by swinging the panel to open position, then lifting directly up. Set aside panel and screw with access doors and posts.
27. Use a Phillips head screwdriver to remove the four (4) screws securing the jacket top panel (item 1). Lift off the panel. Set aside the panel and screws.
28. Use a 7mm socket wrench to remove the two (2) M5 hex bolts from the front center rail (item 2), and the three (3) M5 hex bolts from the rear center rail (item 3). Set aside bolts.
29. Check that all wires and hoses connected to the jacket top frame are clear of internal components and other obstructions.
30. Lift off the jacket top frame. Set aside frame on a clean work surface.

CAUTION Make sure all wiring, wiring connections and hoses are clear and not bearing weight when the frame is set down.
31. Use a 10mm socket wrench to remove the two M8 hex bolts (items 4 & 5) connecting the heat exchanger to the rear bracket of the jacket top frame. Lift off bracket. Set aside bracket and bolts.
32. Use a 10mm socket wrench to remove the two M8 hex bolts (items 6 & 7) connecting the heat exchanger to the front bracket of the jacket top frame. Set aside bolts.
33. Lift off air inlet box and front bracket. Set aside.

Remove components for access to heat exchanger — remove water pipes

1. See **Figure 10** for the following:
2. Support the water return pipe. Use a 17mm socket wrench to remove the four (4) M12 hex nuts (item 8) that secure the water return pipe to the heat exchanger. Set aside nuts.
3. Slide the pipe directly away from the heat exchanger until it comes in contact with the flue connection cover. Then lift straight up and away. Set aside pipe.
4. Support the water supply pipe. Use a 17mm socket wrench to remove the four (4) M12 hex nuts that secure the water supply pipe to the heat exchanger. Set aside nuts.
5. Remove pipe and set aside.

Remove components for access to heat exchanger — remove blower/venturi/mixing adapter assembly and burner

WARNING The burner contains ceramic fiber material. Ceramic fibers can be converted into cristobalite in very high temperature applications. Use care when handling the burner, per instructions in the Annual Startup section of the SlimFit Boiler Manual. Failure to comply could result in severe personal injury.

1. See **Figures 11 and 12** on page 10 for the following:
2. Remove the gas line reference tube (item 9) from venturi. Push in the tube and the plastic ring on the tube fitting. While the ring is pushed in, pull out the tube.
3. Use a Torx wrench to remove the four (4) Torx screws (item 12) that secure the venturi to the gas manifold (item 13). Support the four (4) M5 hex nuts so they do not fall when the screws are removed. Set aside screws and nuts.

Figure 9 Remove jacket top frame, brackets and air inlet box.

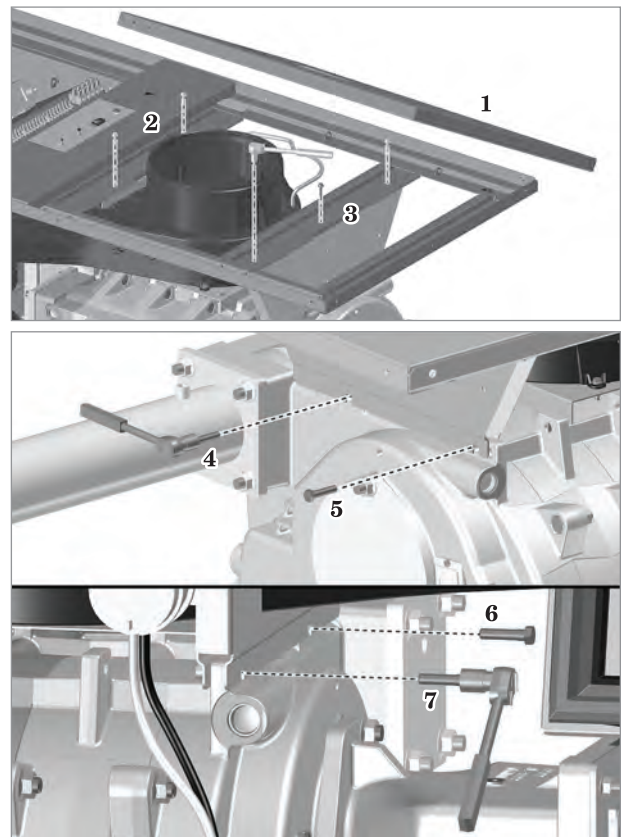

Figure 10 Position of nuts for the water supply and water return pipes.

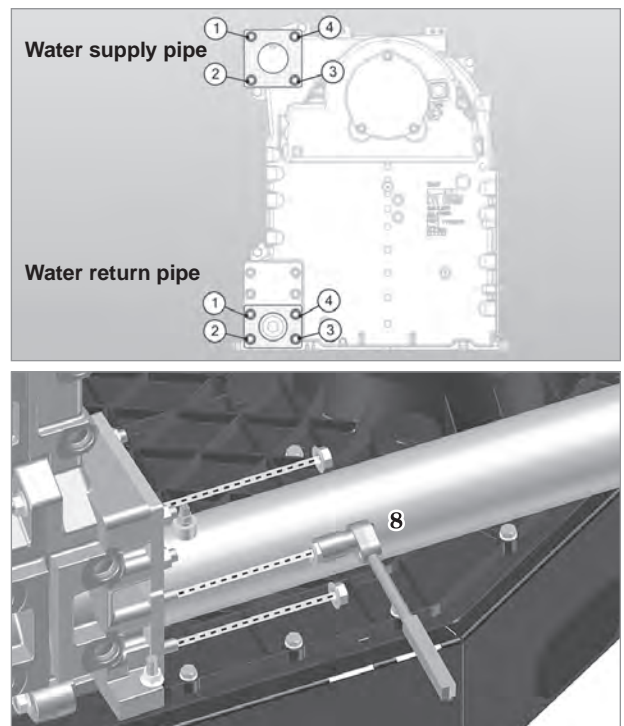
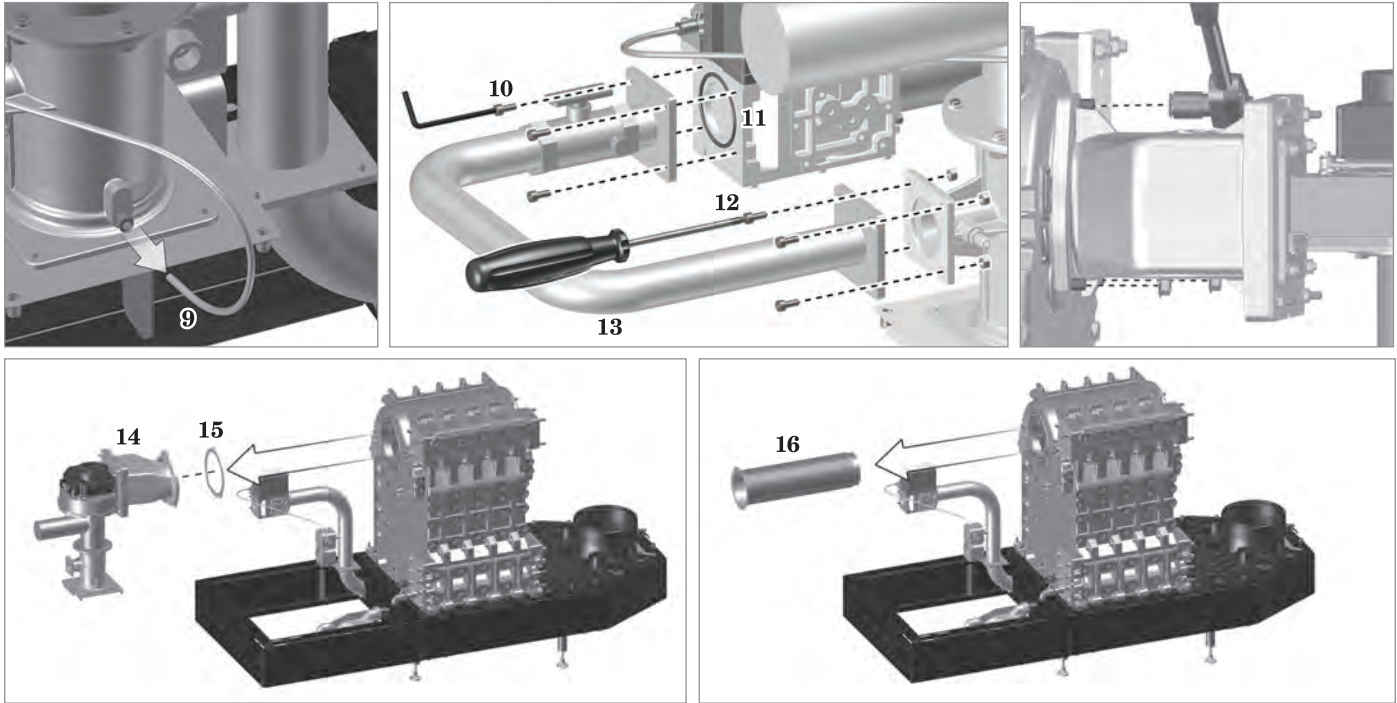



Figure 11 Remove all connections to blower/venturi assembly. Remove blower/venturi assembly and burner from boiler.



- Support the gas manifold. Use a 4mm Allen wrench to remove the four (4) M5 bolts (item 10) that secure the gas manifold to the automatic gas valve. Set aside manifold and bolts.

CAUTION Make sure O-ring (item 11) remains in position within the automatic gas valve and is not removed.

- Support the blower assembly. Use a 17mm socket wrench to remove the three (3) M12 flange nuts that secure the mixing adapter to the heat exchanger. Set aside nuts.

WARNING The blower/venturi/mixing adapter assembly is heavy, weighing up to 60 pounds on larger units. Handle carefully to avoid possible personal injury or damage to the components.

- Carefully slide the blower/venturi/mixing adapter assembly (item 14) off the M12 studs.

- Set aside assembly on its side in a clean work area.

- Remove the burner end gasket from the machined pocket at the burner end of the mixing adapter (item 15). Inspect for wear and damage. Discard gasket; it will be replaced with gasket included in the replacement kit.

- Remove the burner (item 16):

WARNING There may be sharp edges on and inside the burner. Use proper protection on your hand and arm to prevent possible personal injury.

- Place your hand and/or arm inside the burner for control and stability during removal.
 - Slowly pull the burner out, being careful not to drag the fiber mesh on the casting during the process.
- Inspect the burner. Make sure the burner plate (item 17) and clip (item 18) are secure. If necessary, clean the burner following instructions in the Annual Startup section of the SlimFit boiler manual. Set aside burner in a clean work area.

Figure 12 Complete burner assembly, including burner plate and clip.



Figure 13 Remove cover plate, refractory plate and gasket from piping end of heat exchanger.

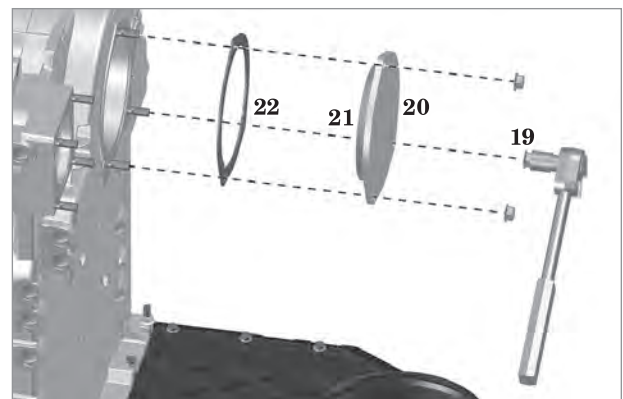
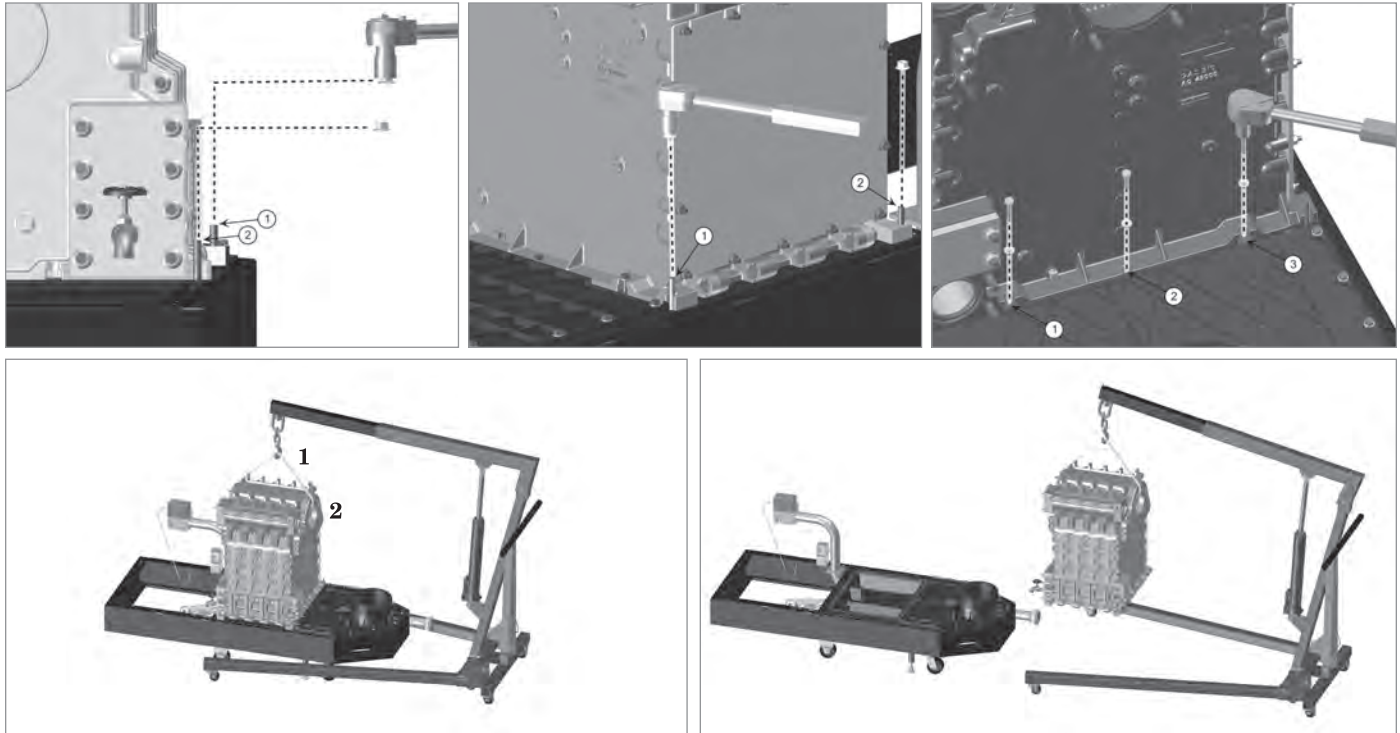



Figure 14 Remove bolts from piping end of heat exchanger. Remove nuts from right and left side. Connect hoist and lift out.



Remove heat exchanger

1. See **Figure 13** for the following:
2. Use a 17mm socket wrench to remove the three (3) M12 hex nuts (item 19) that secure the cover plate to the piping end combustion chamber access. Set aside nuts.
3. Remove cover plate (item 20) and refractory plate with screw-on refractory clip (item 21). Set aside.
4. Remove gasket (item 22). Inspect for wear and damage. Discard gasket; it will be replaced with gasket included in the replacement kit.
5. See **Figure 14** for the following:
6. Use a 17mm socket wrench to remove the two (2) M10 hex nuts on the left side of the heat exchanger.
7. Use a 17mm socket wrench to remove the two (2) M10 hex nuts on the right side of the heat exchanger.
8. Use a 13mm socket wrench to remove the three (3) M8 bolts at the rear of the heat exchanger. Set aside all nuts, bolts and washers.
9. Position the hoist/lifting assembly directly above the center of the heat exchanger.
10. Refer to the Recommended Tools table on page 5 for the weight requirements of the SlimFit boiler model you are repairing. Use a winch strap with a breaking strength of AT LEAST 1-1/2 times the listed weight for your model.

⚠ WARNING Make sure the winch strap is of the rated breaking strength, the heat exchanger is fully secure and the work area is clear before lifting the heat exchanger. Severe personal injury or property damage can occur if the heat exchanger comes loose while being lifted and moved.

⚠ CAUTION DO NOT use a lifting chain for this procedure. The heat exchanger is made of aluminum and may be damaged by contact with a steel chain.

Figure 15 Remove silicone cord gasket from condensate collector.

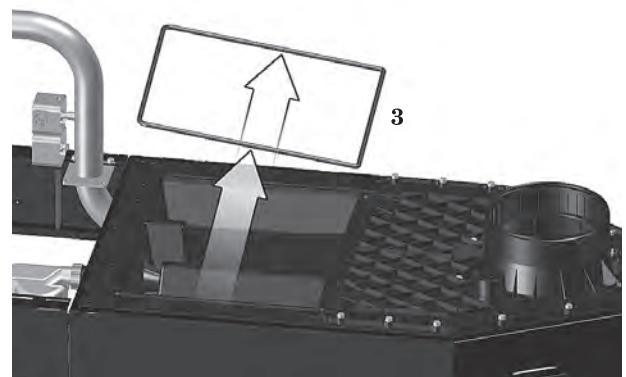



11. Run the winch strap (item 1) through the burner opening (item 2) in the heat exchanger and secure to hoist.
12. Lift the heat exchanger until it is clear of all obstructions and set aside for removal.
13. Remove the silicone cord gasket (Figure 15, item 3) from the condensate collector. Inspect for wear and damage. Discard gasket; it will be replaced with silicone cord included in the replacement kit.
14. See **Figure 16** and Warning sidebar on this page for the following:
15. Install silicone cord included in the replacement kit (item 4) into groove in condensate collector:
 - a. Begin at the midpoint of the burner end of the condensate collector (item 5).
 - b. Apply silicone sealant (item 6) where cord ends meet, and apply an even bead of sealant between the silicone cord and the outer edge of the groove around the entire cord length.

WARNING Make sure all gaskets are installed correctly. Failure to properly install a gasket could result in flue gas or hot water leakage, causing possible substantial property damage, severe personal injury or death.

Install the new heat exchanger

1. See **Figure 14** on the previous page for the following:
2. Use hoist to lift the new heat exchanger onto the base frame.

WARNING Make sure the new heat exchanger is properly seated on the condensate collector gasket. Failure to properly seal the heat exchanger could result in flue gas or hot water leakage, causing possible substantial property damage, severe personal injury or death.

WARNING Make sure all nuts and bolts are tightened to the torque listed in these instructions so that the heat exchanger is properly sealed. Failure to properly seal the heat exchanger could result in flue gas or hot water leakage, causing possible substantial property damage, severe personal injury or death.

3. Reattach the two (2) M10 hex nuts on the left side and the two (2) M10 hex nuts on the right side of the heat exchanger. Tighten nuts to a torque of 7.4 Ft-lbs (10 N-m).
4. Reattach the three (3) M8 bolts and washers to the piping side of the heat exchanger, starting with the center bolt. Tighten bolts to a torque of 1.5 Ft-lbs (2 N-m).
5. See **Figure 7** on page 8 for the following:
6. Reinstall the lower water cutoff probe (Figure 7, item 13). Tighten probe to a torque of 1.5 Ft-lbs (2 N-m).

Reinstall water pipes

1. See **Figure 10** on page 9 for the following:

WARNING Make sure the water pipes are properly seated and completely sealed. Failure to achieve a tight seal could result in hot water leakage, causing possible substantial property damage, severe personal injury or death.

2. Slide the water return pipe onto the four (4) bolts at the base of the piping end of the heat exchanger.
3. Reattach the four (4) M12 hex nuts. Tighten nuts to a torque of 7.4 Ft-lbs (10 N-m).
4. Support the water supply pipe as you slide it onto the four (4) bolts at the upper piping end of the heat exchanger. Reattach the four (4) M12 hex nuts. Tighten nuts to a torque of 7.4 Ft-lbs (10 N-m).

Figure 16 Install new silicone cord gasket.

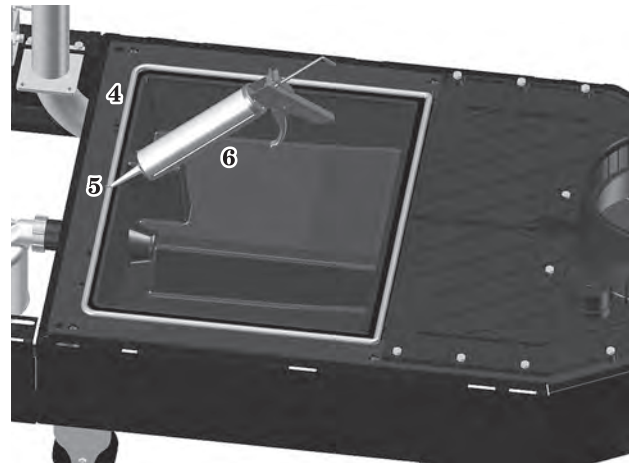

WARNING **Gaskets** — The silicone cord gasket in the condensate collector should **always** be replaced as part of this procedure, regardless of condition, before placing the boiler back in operation.

WARNING Failure to properly install a gasket could result in flue gas or hot water leakage, causing possible substantial property damage, severe personal injury or death.

To install silicone cord gasket:

See Figure 16 on this page for the following.

Do not splice pieces together. The cord must be installed as one continuous piece.

When installing silicone cord, the seam should start near the midpoint of a straight stretch of groove (Figure 16, item 5) to minimize the amount of silicone sealant necessary to complete the seal.

Carefully place the cord along the entire length of the groove without kinking or stretching. Do not stretch the cord around corners.

Cut cord so ends meet as tightly and cleanly as possible. Do not overlap.

Apply a small dab of silicone sealant (Figure 16, item 6) where the ends meet. Run an even bead of sealant around the entire length of cord between the gasket and the outer edge of the groove.

Perform hydrostatic pressure test

Pressure test boiler before permanently attaching water or gas piping or electrical supply.

NOTICE

A pressure test should be performed on site to 1-1/2 times the pressure setting of the relief valve that has been installed on the unit (45 psig for a 30-psig relief valve; 75 psig for a 50-psig relief valve; or 150 psig for a 100-psig relief valve).

Prepare boiler for pressure test

1. See **Figure 17** for the following: Use pipe dope sparingly.
2. Remove relief valve (item 1) and external piping from the 1-1/4-inch tapping on top of the water supply pipe.
3. If a pressure & temperature gauge is not already installed, apply pipe dope to a gauge (supplied by others) and install in the 1/4-inch tapping in the water supply pipe (item 2).
4. Apply pipe dope to a 1-1/4-inch plug and install in the relief valve tapping (item 3) on top of the water supply pipe.
5. At the external flanges to the water return and water supply pipes, temporarily attach a 3-inch ANSI blind flange with tapping for a nipple and valve as shown (items 4 & 5 — flanges, valves, gaskets and nipples supplied by others).
6. Attach a drain line (item 7, supplied by others) to the water supply pipe.
7. Attach a water supply (item 8) and hand pump (not shown, piping and pump supplied by others) to the water return pipe.

Fill boiler and pressure test

1. Open the shutoff valves installed on the water supply (item 6) and water return (item 9) connections.
2. Allow water to flow into the water return connection and air to flow out the water supply connection.
3. When water reaches the water supply shutoff valve (item 6), allow water to flow long enough to ensure all air is out of the heat exchanger. Then close the valve.
4. Close off the water supply and use the hand pump to raise the water pressure for testing. The test pressure should be 1-1/2 times the pressure setting of the relief valve installed on the boiler (45 psig for a 30-psig relief valve; 75 psig for a 50-psig relief valve; or 150 psig for a 100-psig relief valve).

WARNING The test pressure **MUST NOT** exceed the maximum pressure on the pressure & temperature gauge. If test pressure will be higher than the maximum range of the P/T gauge, use a different gauge for the test.

5. Gradually apply pressure until test pressure is reached. Then close off the shutoff valve.
6. Hold at test pressure for 10 minutes.

WARNING Do not leave boiler unattended. A cold water fill could expand and cause excessive pressure, resulting in severe personal injury, death or substantial property damage.

7. Make sure that constant gauge pressure has been maintained throughout test.
8. Check for leaks. Repair if found.

Figure 17 Remove relief valve and perform hydrostatic pressure test (all external components supplied by others).

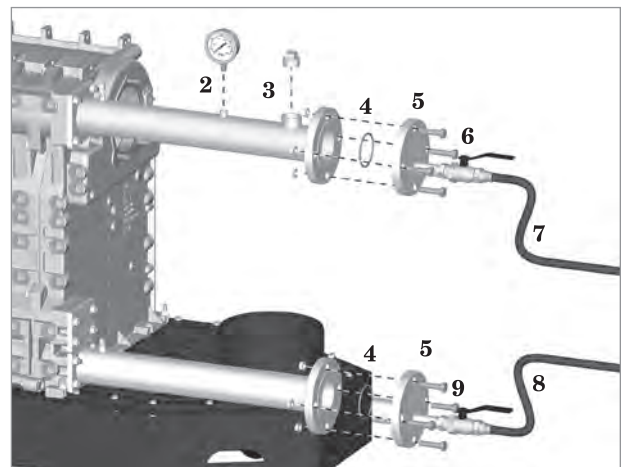
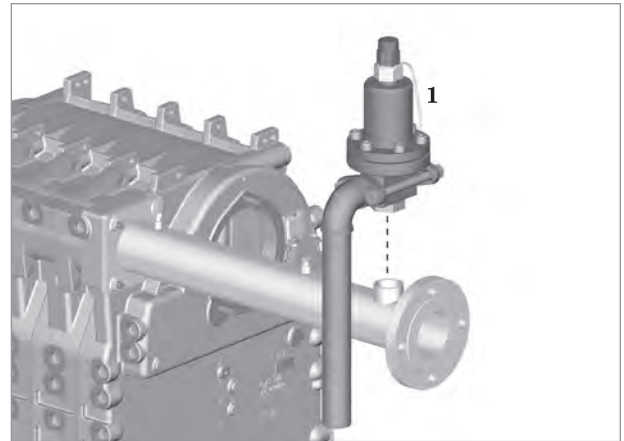

WARNING **Leaks must be repaired at once.** Failure to do so can damage boiler, resulting in substantial property damage.

WARNING **Do not use petroleum-based** cleaning or sealing compounds in boiler system. Gaskets and seals in the system may be damaged. This can result in substantial property damage.



Drain and remove fittings

1. Disconnect fill water hose from water source.
2. Open the water supply shutoff valve (Figure 17, item 6).
3. Drain boiler through the water return shutoff valve (Figure 17, item 9).
4. Remove hoses or drain piping after draining.
5. Remove the blanking flange/valve assemblies from the water return and water supply pipe flanges.
6. Remove plug (Figure 17, item 3) from the 1-1/2-inch tapping on top of the water supply pipe and reinstall the pressure relief valve (Figure 17, item 1).
7. See **Figure 18** for the following:
8. If there is no drain valve installed off of the return piping, install a 3/4-inch boiler drain valve in the 3/4-inch tapping at the lower burner end of the heat exchanger.

Reinstall the burner

1. See **Figure 19**, as well as **Figures 11 and 12** on page 10, for the following.
2. Carefully insert the burner. Avoid dragging fiber mesh as it is inserted into combustion chamber.
3. Align notches at the 5 and 7 o'clock positions on the burner flange (item 1) with the small dowel pins (item 3) on the heat exchanger.
4. Burner flange should fit into machined pocket (item 2) in end section of heat exchanger. Burner should tilt down slightly once it is fully inserted.

Reinstall the blower/venturi/mixing adapter assembly

1. See **Figures 11 and 13** on page 10 for the following.
2. Slide the burner end gasket (Figure 11, item 15) over the machined profile at the burner end of the mixing adapter so that the three holes line up and the gasket is tight against the adapter.

WARNING The blower/venturi/mixing adapter assembly is heavy, weighing up to 60 pounds on larger units. Handle carefully to avoid possible personal injury or damage to the components.

3. Carefully slide the blower/venturi/mixing adapter assembly (Figure 11, item 14) over the M12 studs until the burner end gasket is tight against the burner flange.
4. Reinstall the three (3) M12 flange nuts on the mixing adapter. Tighten nuts to a torque of 22 Ft-lbs (30 N-m).
5. Fully support the assembly until all three nuts are fully torqued.
6. **Check that the O-ring (Figure 11, item 11) is in position within the automatic gas valve.** Line up the gas manifold (Figure 11, item 13) and reinstall the four (4) M5 bolts (Figure 11, item 10) that secure the gas manifold to the automatic gas valve. Tighten bolts to a torque of 53 in-lbs (6 N-m).
7. Reinstall the four (4) Torx screws (Figure 11, item 12) that secure the gas manifold to the venturi.

WARNING Make sure all gas connections are completely sealed. Failure to achieve a tight seal could result in gas leakage, causing possible substantial property damage, severe personal injury or death. Reconnect the gas line reference tube (Figure 11, item 9) to the venturi. The fitting will self-tighten on the tube. Test the connection by lightly pulling on the plastic tube.

8. Reinstall the cover plate (Figure 13, items 20 & 21) and new gasket (from kit) (Figure 13, item 22) onto the piping end combustion chamber access. Reattach the three (3) M12 nuts and tighten nuts (Figure 13, item 19) to a torque of 22 Ft-lbs (30 N-m).

Figure 18 Spigot installed (reference only) for drainage using the 3/4-inch tapping on burner end of heat exchanger.

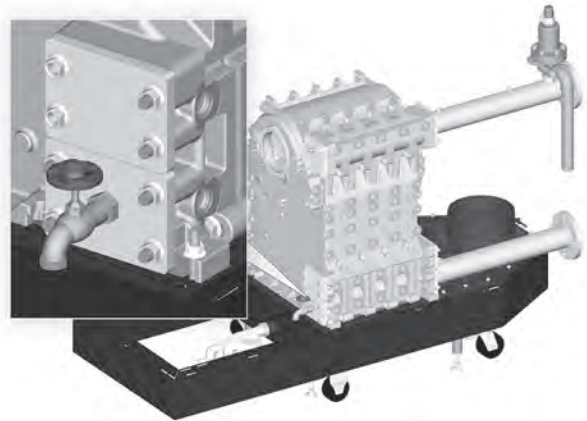
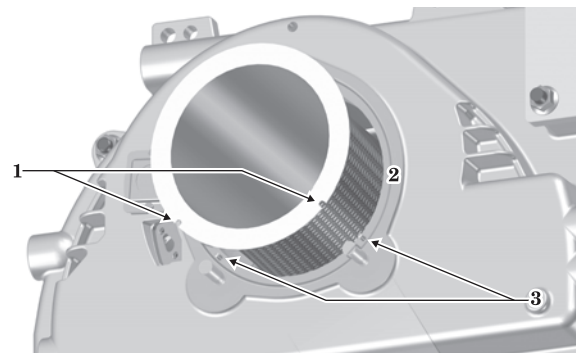

Figure 19 The burner flange fits within the machine pocket in the heat exchanger. The two notches align with the dowel pins.





Reinstall the jacket top frame, heat exchanger brackets and air inlet box

1. See **Figure 9** on page 9 for the following:
2. Reinstall the rear bracket of the jacket top frame to the heat exchanger and tighten the two (2) M8 hex bolts (Figure 9, items 4 & 5).
3. Reinstall front bracket of the jacket top frame to the heat exchanger and slide the air inlet box into place within the bracket so the bolt holes align. Tighten the two (2) M8 hex bolts (Figure 9, items 6 & 7).
4. Lift the jacket top frame so that the front and rear bracket rails align with the bolt holes in the front and rear brackets. Reinstall the two (2) Phillips head screws on the front bracket and the three (3) Phillips head screws on the rear bracket.

CAUTION Make sure that all hoses and wires hang clear once jacket top frame is in place.

5. Reinstall the top jacket panel onto the jacket top frame and tighten the four (4) Phillips head screws.
6. Reinstall the electric access panel onto the jacket top frame. Reinstall the screw to hold electric access panel, securely in place.
7. See **Figure 6** on page 7 for the following:

WARNING The air flow switch hose and gas line reference tube **MUST** be replaced correctly on the venturi.

8. Push the air flow switch tube (white hose, Figure 6, item 1) onto the hose barb on the venturi.
9. Push the flue pressure switch reference line (black hose, Figure 6, item 2) onto the hose barb on the bottom burner end of the heat exchanger.

Reinstall all electrical and hose connections to jacket top frame

1. See **Figure 7** on page 8 for the following:
2. Connect the wire harnesses (Figure 7, items 3 & 4) to the automatic gas valve and the gas pressure switches.
3. Connect the two (2) wiring harnesses (Figure 7, items 5 & 6) into the back of the blower motor.
4. Connect the ring connector (Figure 7, item 12) to the already installed low water cutoff probe (Figure 7, item 13) and reinstall the securing nut.
5. Connect the flue temperature sensor plug (Figure 7, item 19) located on the vent connector into the sensor.
6. Connect the return temperature sensor plug (Figure 7, item 17) located on the water return pipe, into the sensor.
7. Connect the supply temperature sensor plug (Figure 7, item 18) located on the water supply pipe, into the sensor.
8. Reinstall the block temperature switch (Figure 7, item 8), located at the burner end of the heat exchanger. Connect the red two-pronged plug (Figure 7, item 9).
9. See **Figure 20**, as well as **Figure 7** on page 8, for the following.
10. Retrieve the ignitor (item 4) and flame sensor (item 5) assemblies.

NOTE DIFFERENCES: ignitor has a longer electrode and a brown ceramic insulator, while flame sensor has a shorter electrode and pink ceramic insulator.

CAUTION The ignitor must be installed on the burner end section of the heat exchangers. The flame sensor must be installed on the piping end section. Installing these components in the wrong locations could cause poor ignition and lockout, resulting in loss of heat.

Figure 20 Distinguishing features of the ignitor (item 4) and the flame sensor (item 5).





11. Reinstall the two (2) screws holding the ignitor (Figure 7, item 11) in place next to the mixing adapter on the burner end of the heat exchanger. Make sure the gasket is correctly positioned.
12. Make sure the green grounding wire (Figure 7, item 10) is under the top screw and locking washer that secure the ignitor to the casting.
13. Reconnect the plug (Figure 7, item 7).
14. Reinstall the two (2) screws holding the flame sensor (Figure 7, item 14) in place next to the combustion chamber access cover on the piping end of the heat exchanger. Make sure the gasket is correctly positioned.
15. Make sure the green grounding wire (Figure 7, item 15) is under the top screw and locking washer that secure the ignitor to the casting.
16. Reconnect the plug (Figure 7, item 16).
17. See **Figure 8** on page 8 for the following:
18. Reconnect the air inlet hose to the air inlet box (Figure 8, item 20) by pushing up and rotating until it locks into place.
19. Reconnect the air inlet hose to the venturi.
 - a. SF1000/SF1500: reinstall the four(4)M5 flange bolts (Figure 8, item 21). Tighten bolts to a torque of 53 in-lbs (6 N-m).
 - b. SF2000: reinstall the four(4)M8 flange bolts (Figure 8, item 21). Tighten bolts to a torque of 53 in-lbs (6 N-m).

Return boiler to its installed location

1. See **Figure 5** on page 7 for the following:
2. Adjust the four (4) leveling legs upward until the four (4) casters can move freely.
3. The piping end casters are swivel type. The burner end casters are fixed.
4. Roll the boiler back to its installed location.
5. Adjust the leveling legs down until the casters are clear of the floor and the bottom of the boiler base is 5-1/4 inches above the floor.

WARNING The wheels **MUST** be lifted off the ground once the boiler has been situated. The boiler should not rest on the casters. The minimum distance from the bottom of the base frame to the floor must be no less than 5-1/4 inches.

NOTICE If the boiler is mounted on mounting blocks, remove the casters and reinstall into existing mounting holes.

Reconnect boiler to external water piping, gas and electricity.

1. Inspect the boiler thoroughly to ensure all components are properly reinstalled.
2. See **Figures 3 and 4** on page 6 for the following:
3. Reinstall the four (4) hex nuts and bolts securing external piping to water supply pipe (Figure 3, item 2) and water return pipe (Figure 3, item 3).
4. Reconnect air piping to air intake (Figure 4, item 4) and vent piping to vent connection (Figure 4, item 5) by lowering pipes into place and rotating until tight.
5. Reconnect field wiring to terminal strips.
6. Reconnect the gas supply piping at union.

WARNING Use two (2) pipe wrenches when connecting the gas line to prevent damage to the piping or gas line components.

Reinstall all access doors and jacket posts

1. See **Figure 2** on page 6 for the following:
2. Slide flange at bottom of each jacket corner post into slot at corner of base frame. Use a Phillips head screwdriver to reinstall the two (2) screws (Figure 2, item 1) connecting jacket corner post to the jacket top frame.
3. Slide jacket side posts into place by aligning top and bottom flanges with slots in jacket top frame and base frame.
4. Reinstall the six (6) access doors by sliding into place.

Start up, test and adjust boiler

1. **Refer to Boiler Manual for proper startup procedure.**
2. Follow all instructions in the Boiler Manual to start up, test and adjust the boiler.

WARNING Removing and reinstalling components can change boiler behavior. After any maintenance procedure, you must prove the boiler is operating correctly. To do so, follow the complete procedure for boiler and system start-up as instructed in the Boiler Manual. Failure to comply could result in severe personal injury, death or substantial property damage.